



**SUPERIOR**<sup>®</sup>  
A SHERWOOD COMPANY

# SUPERIOR HVACR PRODUCTS CATALOG





## A History of Quality and Innovation

*For nearly a century, Superior has been the world's leading provider of HVACR valves and accessories.*

Over the last 90 years, we've earned a reputation for products that not only keep pace with customer requirements, but also anticipate their changing needs. Our expert engineering and product development teams continuously work to improve core competencies and create new, innovative products to meet the industry's ever-changing standards and demands.

Superior was bought by Sherwood Valve in 1998. Today Sherwood Valve has three manufacturing facilities near Pittsburgh, PA and Cleveland, OH.

### **Manufacturing Quality, Safety and Reliability**

Automated manufacturing processes throughout Sherwood's operations are set up to reduce touch labor, resulting in consistently higher-quality products. We're using the latest technology available to lower costs and increase quality. For example, we've recently invested in new advanced machinery, including two robotic ball valve welding machines. The robotic machinery provides top weld control and unlimited flexibility for a variety of welding variables, thus eliminating extraneous processes and reducing production costs.

Sherwood is a totally integrated brass valve manufacturer. We manufacture our own rod and raw forgings at our foundry. These forgings are then machined into the bodies that we use in the majority of our valves. Because we manufacture our own brass rod, we can control the alloy components more closely, resulting in a more durable forging.

All Sherwood products are designed to meet the highest standards, and only quality materials are used. Careful assembly and detailed inspection of every part ensures top performance and durability. Sherwood is fully certified to the stringent requirements of ISO 9001, which increase manufacturing efficiency and reliability.

### **Your Valve Partner**

Beyond HVACR, Sherwood's diverse product lines for the specialty gas, packaged gas, life & safety and alternative energy markets have enabled us to develop varied and diverse technical expertise. Our engineering team includes experts in product design and development as well as experts in the quality and compliance testing requirements needed to create custom valves to meet your unique applications.

Sherwood is partnered with a solid network of worldwide industry leaders, distributors, manufacturing representatives and customers supporting continuous improvement. We know valves are a system-critical piece of your business and we're proud to provide you with American-made products and service you can trust. Superior — A Sherwood Company is your partner for the best quality HVACR valves, delivered on time, at the best possible price!



**Contents**

**Page**

High-Performance Ball Valves ..... 2-3

WA/WAS Series Ball Valves ..... 4-5

MST Series Ball Valves ..... 5

VRF Series Ball Valves ..... 6

Tuffy Series Line Valves ..... 7-10

H-V Check Valves ..... 11-15

In-Line Magnetic Check Valves ..... 16

Dual Pressure-Relief Valve Series and Assembly ..... 17-18

Pressure-Relief Valves ..... 19-21

Selection of Relief Valves ..... 22-23

Packed Angle Valves ..... 24-27

CFA Uni-Form® Shells ..... 28

Suction Line Filters ..... 29-34

Liquid Line Cores ..... 35

Spare Parts List ..... 36-37

Codes, Regulations and Specifications ..... 38



## High-Performance Ball Valves

### High-Performance Ball Valves – The Green Solution to Minimize Access Port Leaks

- Virtually eliminate refrigerant system leaks.
- 700 PSIG working pressure.
- Designed for refrigeration applications.
- Full open to full close with a ¼ turn.
- Patent pending.
- Durable aluminum handwheel.

- Forged brass body.
- Refrigeration service temperature from -40° F to +300° F.
- UL®, cUL and CE Compliant.
- For use with CO<sub>2</sub>, CFC, HFC and HCFC refrigerants listed in CAN/CSA B52 and ANSI/ASHRAE 15 Section 9.2.

#### 586WBSR-6M – 3/8" Connection

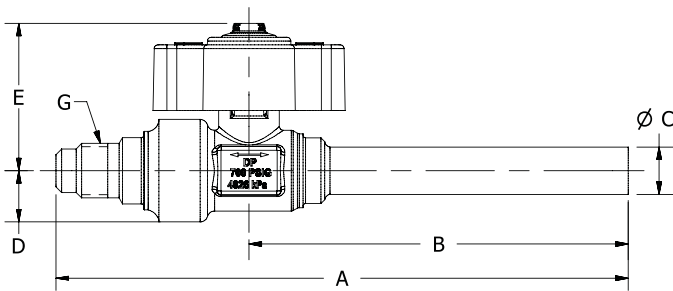

**Application:** Replaces header access fitting on refrigeration rack systems and condensing units. Provides superior leak protection.

#### 586WBR-6M4FP – 3/8" Connection

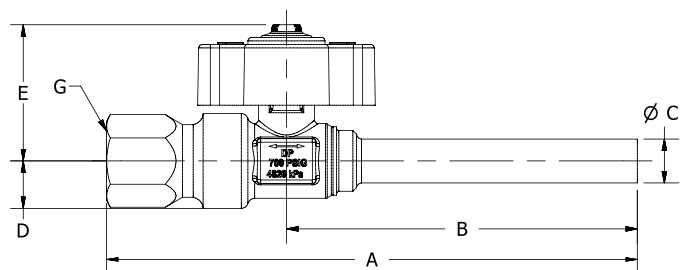

**Application:** Service port with functionality to connect ancilliary devices.

#### 586WBSR-6M2FP – 3/8" Connection

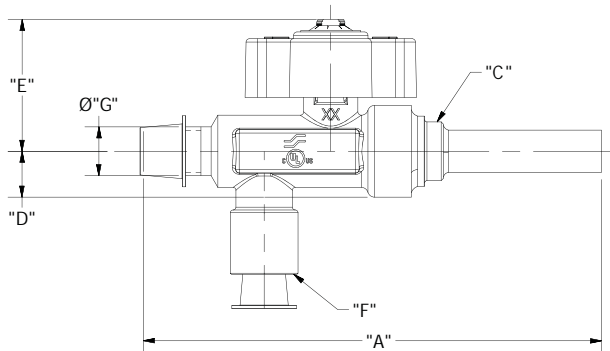

**Application:** Service valve with capability to connect pressure transducer and provides full off or on flow for maintenance.

#### 586WBR-6M6FL – 3/8" Connection

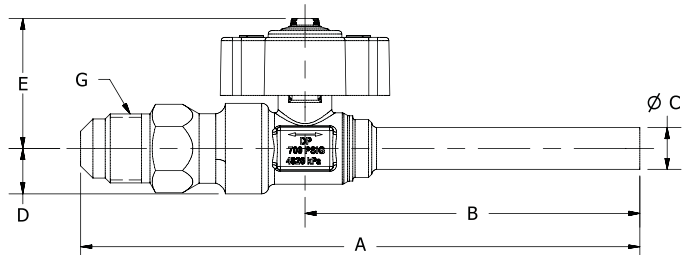

**Application:** Service port with higher flow capabilities to charge or evacuate the system.

## High-Performance Ball Valves – The Green Solution to Minimize Access Port Leaks

### 586WBSR-4MP – 1/4" Connection

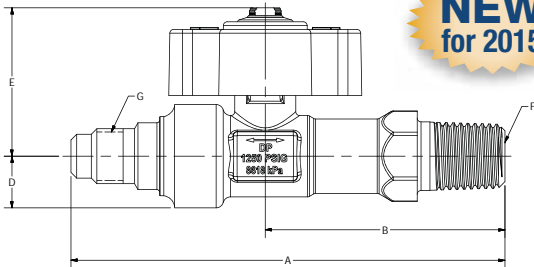

**Application:** Replaces header access fitting on refrigeration rack system and condensing units.

### 586WBR-6SW6FL – 3/8" Connection

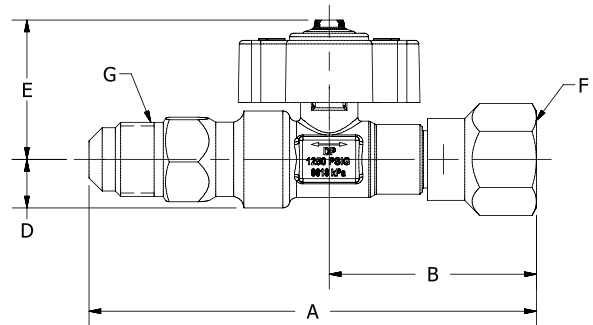

**Application:** Installs on an existing access port to stop leakage or to service system.

### 586WBSR-4SW4FL – 1/4" Connection

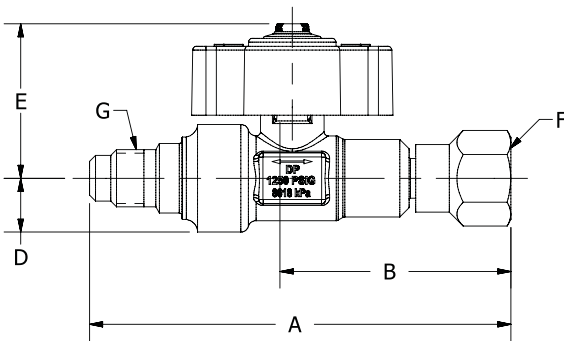

**Application:** Installs on an existing access port to stop leakage or to service system.

### 586WBR-4ST – 1/4" Connection

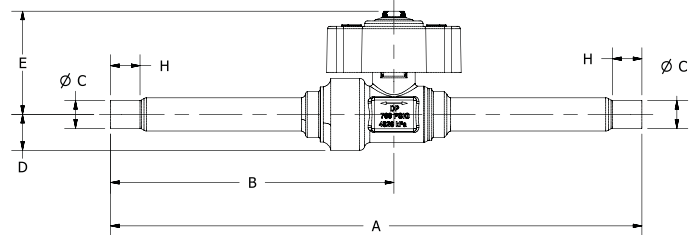

**Application:** Line set ball valve for high-frequency on/off use where higher flow is required.

### 586WBR-6ST – 3/8" Connection

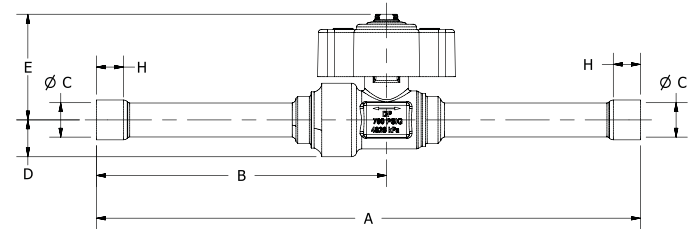

**Application:** Line set ball valve for high-frequency on/off use where higher flow is required.

Part Number	IBCA Number	Dimensions								Weight
		A	B	C - Connection	D	E	F - Connection	G - Connection	H	
586WBSR-4MP	30750	3.41	1.89	—	0.41	1.17	1/4" NPTF	1/4" SAE	—	0.26
586WBSR-6M	29770	4.53	3.00	0.375 ODM	0.41	1.17	1/4" NPTF	1/4" ACCESS	—	0.22
586WBSR-6M2FP	29771	3.96	2.40	0.375 ODM	1.09	1.17	1/8" NPTF	1/4" ACCESS	—	0.29
586WBSR-4SW4FL	29772	3.18	1.65	—	0.41	1.17	1/4" SAE	1/4" ACCESS	—	0.25
586WBR-6SW6FL	29795	3.74	1.73	—	0.41	1.17	3/8" SAE	3/8" SAE	—	0.37
586WBR-6M4FP	29776	4.54	3.00	0.375 ODM	0.41	1.17	—	1/4" NPTF	—	0.23
586WBR-6M6FL	29777	5.01	3.00	0.375 ODM	0.41	1.17	—	3/8" SAE	—	0.29
586WBR-4ST	29774	6.00	3.20	0.25 ODS	0.41	1.17	—	—	0.31	0.19
586WBR-6ST	29775	6.00	3.20	0.375 ODS	0.41	1.17	—	—	0.31	0.19

WA/WAS Series Ball Valves

**INTEGRA-SEAL®**

**WA Series — No Access Fitting**

**WAS Series — Includes Access Fitting**

A robotically welded body joint. Full-size ports for unrestricted flow. These ball valves employ the latest robotic welding technology. Every continuous welded body joint is 100% factory tested to ensure positively leak-free performance. Dual Teflon® ball seals surround a polished brass or carbon steel ball at each end. A secondary seal becomes effective if foreign material scores the primary seal — even in extremely unfavorable conditions such as compressor burnout — a Superior exclusive!

WA/WAS Series Ball Valves are constructed using a forged brass body with copper tube extensions on all sizes. Mechanical internal forged stops ensure positive open or closed positions — another Superior exclusive. Full open to full close with ¼ turn.

All sizes incorporate a dual stem seal design utilizing Teflon packing compressed by an internal packing nut forming the primary seal. The unique seal cap design permits valve operation without removal of the seal cap and uses

Teflon gaskets to provide a secondary seal — a third Superior exclusive! There are no synthetic O-rings. Ball internal relief port design ensures shut-off in either direction of flow — even during evacuation of the system. Full flow ports in all sizes ⅜" through 3⅛". These ball valves are non-directional flow valves and may be installed in any position.

*Teflon is a registered trademark of Dupont.*

*\* Metric sizes available upon request.*

**WA Series**

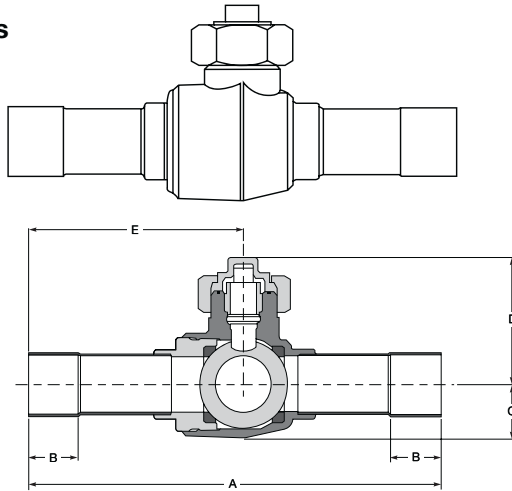

**WAS Series (with Access Fitting)**

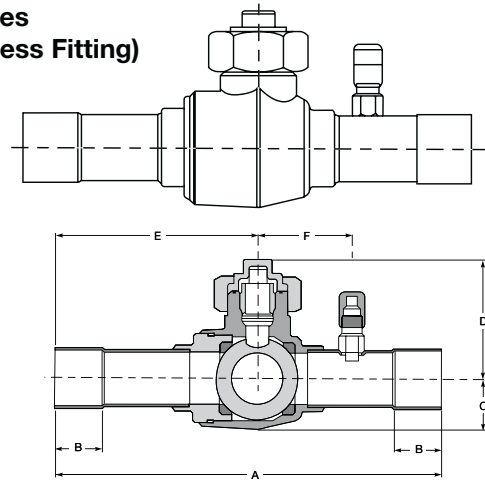

Without Access Fitting	IBCA Number	With Access Fitting	IBCA Number	Connection (ODS)	Ball Port Diameter	Weight (lbs.) WA	Weight (lbs.) WAS
586WA-4ST	23767	—	—	¼	0.50	0.7	N/A
586WA-6ST	58651	586WAS-6ST	59726	⅜	0.50	0.7	0.77
586WA-8ST	58652	586WAS-8ST	59727	½	0.50	0.7	0.77
586WA-10ST	58564	586WAS-10ST	59728	⅝	0.50	0.7	0.77
587WA-12ST	58659	—	—	¾	0.75	1.0	N/A
587WA-14ST	58584	587WAS-14ST	59729	7/8	0.75	1.0	1.10
591WA-11ST	58756	591WAS-11ST	59730	1½	1.00	2.2	2.42
592WA-13ST	58790	592WAS-13ST	60072	1¾	1.50	3.8	4.18
593WA-15ST	58793	593WAS-15ST	59731	1¾	1.50	3.8	4.18
594WA-21ST	58865	594WAS-21ST	59732	2½	2.01	8.0	8.80
594WA-25ST**	58864	—	—	2½	2.01	11.0	N/A
594WA-31ST**	58863	—	—	3½	2.01	11.0	N/A
595WA-25ST	60235	595WAS-25ST	60316	2½	2.44	15.0	15.80
596WA-31ST	59143	596WAS-31ST	59733	3½	2.91	25.0	26.00
596WA-35ST**	59146	—	—	3½	2.91	26.0	N/A
596WA-41ST**	59150	—	—	4½	2.91	27.0	N/A

\*\* Reduced ports.



**Seal Cap**

Exclusive Seal Cap design permits operation of valve without removal. Markings on cap top designate at-a-glance open or closed ball position.

**WA Series — No Access Fitting**

**WAS Series — Includes Access Fitting**

**MST Series — Male Soldered Tube**

- Full refrigeration service temperature range of -40° F to +325° F (-40° C to +149° C).
  - Design working pressure: 700 PSIG.
  - UL® and cUL Listed, File No. SA3462 (N), except for metric sizes and oxygen.
  - WAS Series includes access fitting, strategically located on tube extension.
  - No synthetic O-ring seals. Double seal protection provides a Superior stem design.
  - Polished brass or carbon steel ball.
  - Forged brass body and seal cap.
  - Seal cap design permits valve operation without removal of seal cap.
  - For use with CO<sub>2</sub>, CFC, HFC and HCFC refrigerants listed in CAN/CSA B52 and ANSI/ASHRAE 15 Section 9.2.
  - Spare Parts List on pp. 36–37.
- \* Metric sizes available upon request.*

Without Access Fitting	With Access Fitting	Dimensions (Inches)						Maximum Width	C <sub>v</sub>
		A	B	C	D	E	F		
586WA-4ST	—	6.50	0.31	0.56	1.80	3.44	N/A	1.38	N/A
586WA-6ST	586WAS-6ST	6.50	0.31	0.56	1.80	3.44	1.75	1.38	3.60
586WA-8ST	586WAS-8ST	6.50	0.38	0.56	1.80	3.44	1.75	1.38	7.40
586WA-10ST	586WAS-10ST	6.50	0.50	0.56	1.80	3.44	1.75	1.38	14.60
587WA-12ST	—	6.56	0.63	0.73	1.96	3.46	N/A	1.88	22.30
587WA-14ST	587WAS-14ST	6.56	0.75	0.73	1.96	3.46	1.75	1.88	30.00
591WA-11ST	591WAS-11ST	7.69	0.94	1.03	2.37	4.01	1.75	2.31	62.00
592WA-13ST	592WAS-13ST	8.88	1.00	1.42	2.73	4.49	2.21	3.19	110.00
593WA-15ST	593WAS-15ST	9.13	1.09	1.42	2.73	4.62	2.21	3.19	135.00
594WA-21ST	594WAS-21ST	9.88	1.34	1.85	3.11	5.07	2.57	4.06	270.00
594WA-25ST**	—	12.88	1.44	1.85	3.11	6.57	N/A	4.06	250.00
594WA-31ST**	—	13.75	1.63	1.85	3.11	7.01	N/A	4.06	240.00
595WA-25ST	595WAS-25ST	12.92	1.50	2.30	3.95	6.52	3.35	4.65	340.00
596WA-31ST	596WAS-31ST	16.31	1.69	2.75	4.35	8.32	3.63	5.63	480.00
596WA-35ST**	—	16.03	1.94	2.75	4.35	8.32	N/A	5.63	455.00
596WA-41ST**	—	16.03	1.94	2.75	4.35	8.32	N/A	5.63	430.00

\*\* Reduced ports.

**MST Series — Male Soldered Tube**

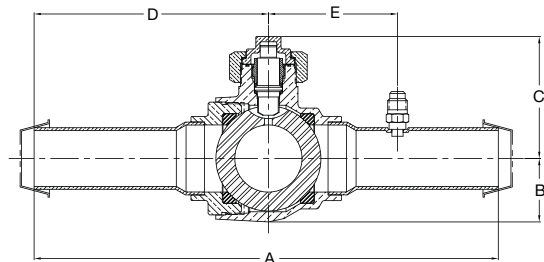
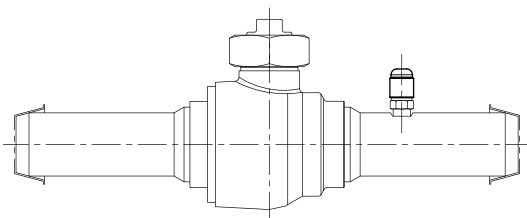

Part Number	IBCA Number	Male Connection (ODS)	Ball Port Diameter	Weight (lbs.)	Dimensions (Inches)					Maximum Width	C <sub>v</sub>
					A	B	C	D	E		
586WAS-10MST	30172	3/8"	0.50	0.76	8.00	0.56	1.80	4.19	1.68	1.38	14.60
587WAS-14MST	30173	1/2"	0.75	1.08	8.00	0.73	1.96	4.18	1.83	1.88	30.00
591WAS-11MST	30177	1 1/8"	1.00	2.49	12.47	1.03	2.37	6.41	2.31	2.31	62.00
592WAS-13MST	30175	1 1/4"	1.50	3.91	10.36	1.42	2.73	5.23	2.88	2.88	110.00
593WAS-15MST	30176	1 3/8"	1.50	4.10	10.14	1.42	2.73	5.12	3.02	3.02	135.00
594WAS-21MST	30157	2 1/4"	2.01	7.94	12.25	1.85	3.11	6.25	3.50	3.50	270.00



SWD0215 ©2015 Sherwood Valve, LLC



www.sherwoodvalve.com • 888.508.2583

VRF Series Ball Valves

**VRF Ball Valve Series — Improved Unibody Design Minimizes Leaks**

**Flare and ODS Connection Ball Valves for Use with VRF Systems**

- Offered in both flare connections and ODS copper tube connections
- Exclusive Sherwood uni-body design eliminates leak points
- Full port design
- 700 PSIG Rated
- Offered with optional fully factory assembled insulation wrap
- Each ball valve is factory tested under pressure
- Equipped with access fitting for refrigerant service
- Forged brass body and seal cap
- Uses polytetrafluoroethylene (PTFE) seals and gaskets (no synthetic O-rings)
- Seal cap design permits valve operation without removal of seal cap
- Sizes available: 1/4", 3/8", 1/2", 5/8"
- Temperature range: -40° F to +325° F (-40° C to +149° C)
- Suitable for use with R-11, R-22, R-123, R-125, R-134A, R-236FA, R-4202A, R-402B, R-404A, R-407C, R-410A, R-500, R-502 and R-507

**ODS x ODS Connection Valve**

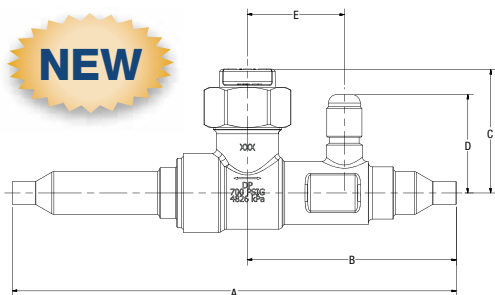

**ODS x ODS Ball Valve Factory Wrapped in Foam Insulation**

Part Number	Size (Inches)	Part Number	Size (Inches)
586WBS-4SWSP	1/4 ODS x 1/4 ODS	586WBS-8SWSP	1/2 ODS x 1/2 ODS
586WBS-6SWSP	3/8 ODS x 3/8 ODS	586WBS-10SWSP	5/8 ODS x 5/8 ODS

**ODS x ODS Ball Valve**

Part Number	IBCA Number	Size (Inches)	Dimensions (Inches)				
			A	B	C	D	E
586WBS-4SW	30441	1/4 ODS x 1/4 ODS	6.5	3.06	1.8	1.44	1.42
586WBS-6SW	30442	3/8 ODS x 3/8 ODS	6.5	3.06	1.8	1.44	1.42
586WBS-8SW	30443	1/2 ODS x 1/2 ODS	6.5	3.06	1.8	1.44	1.42
586WBS-10SW	30444	5/8 ODS x 5/8 ODS	6.5	3.06	1.8	1.44	1.42

**Flare x Flare Connection Valve**

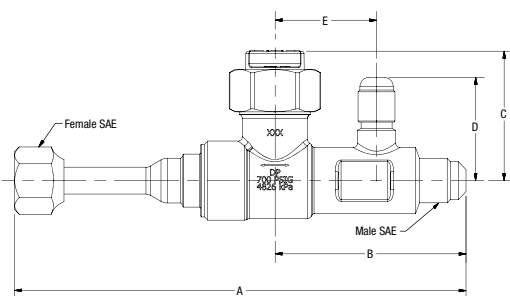

**Flare x Flare Ball Valve Factory Wrapped in Foam Insulation**

Part Number	Size (Inches)	Part Number	Size (Inches)
586WAS-4FLSP	1/4 M SAE x 1/4 F SAE	586WAS-10FLSP	5/8 M SAE x 5/8 F SAE
586WAS-6FLSP	3/8 M SAE x 3/8 F SAE	586WAS-6MX4F-FLSP	3/8 M SAE x 1/4 F SAE
586WAS-8FLSP	1/2 M SAE x 1/2 F SAE	586WAS-10MX8F-FLSP	5/8 M SAE x 1/2 F SAE

**Flare x Flare Ball Valve**

Part Number	IBCA Number	Size (Inches)	Dimensions (Inches)				
			A	B	C	D	E
586WAS-4FL	28181	1/4 M SAE x 1/4 F SAE	6.19	2.60	1.80	1.22	1.42
586WAS-6FL	28182	3/8 M SAE x 3/8 F SAE	6.30	2.67	1.80	1.22	1.42
586WAS-8FL	28183	1/2 M SAE x 1/2 F SAE	6.51	2.67	1.80	1.22	1.42
586WAS-10FL	28184	5/8 M SAE x 5/8 F SAE	6.64	2.67	1.80	1.28	1.42
586WAS-6MX4F-FL	30712	3/8 M SAE x 1/4 F SAE	6.26	2.67	1.8	1.44	1.42
586WAS-10MX8F-FL	30713	5/8 M SAE x 1/2 F SAE	6.51	2.67	1.8	1.44	1.42

**Individual Foam Insulation**

Part Number	Size (Inches)
P586WAS-FOAMSP	.5 thick x 8.75 L

**VRF Flare Ball Valve Kit**

Part Number	Description
586WBS-6/10FL	Includes 586WAS-6FL with 3/8" x 1/4" flare adapter and 586WAS-10FL with 5/8" x 1/2" flare adapter



## Tuffy Series

### Diaphragm Packless Line Valves

All diaphragm packless valves contain metal diaphragms and backseat metal-to-metal when the valve is fully open. Controlled stem travel assures lifetime diaphragm performance. Balanced bearing surfaces and polished stem heads eliminate wear and assure smooth, easy operation. Flow is unrestricted. All OD solder connections for valves  $\frac{5}{8}$ " and smaller are machined to an outside diameter

equivalent to the next largest standard size of tubing. Because of their unique construction, Superior diaphragm packless valves can be soldered into the line without disassembly. "Comfortgrip" nylon handwheels are furnished on all types of valves.

All Tuffy Series Line Valves are designed to be installed in the direction of the flow arrow.

### Vacuum Applications

All Superior packless valves are excellent for vacuum service down to 200 microns.

### Tuffy Straight-Thru Valves

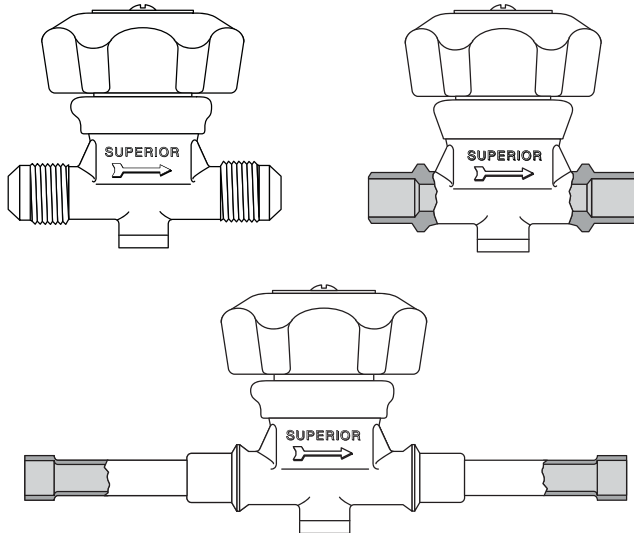

Part Number	IBCA Number	Size (Inches)		Weight (lbs.)
		Inlet	Outlet	
<b>Tuffy Standard</b>		SAE	x SAE	
214-4	56381	$\frac{1}{4}$	$\frac{1}{4}$	0.50
214-6	56384	$\frac{3}{8}$	$\frac{3}{8}$	0.50
215-8	56400	$\frac{1}{2}$	$\frac{1}{2}$	1.00
216-10	56409	$\frac{3}{4}$	$\frac{3}{4}$	1.00
<b>Tuffy Standard</b>		ODS	x ODS	
214-4S	56382	$\frac{1}{4}$	$\frac{1}{4}$	0.50
214-6S	56385	$\frac{3}{8}$	$\frac{3}{8}$	0.50
215-8S	56401	$\frac{1}{2}$	$\frac{1}{2}$	1.00
216-10S	56410	$\frac{3}{4}$	$\frac{3}{4}$	1.00
<b>Tuffy w/Tube Exts.</b>		ODS	x ODS	
214-4ST	56383	$\frac{1}{4}$	$\frac{1}{4}$	0.75
214-6ST	56387	$\frac{3}{8}$	$\frac{3}{8}$	0.75
215-8ST	56402	$\frac{1}{2}$	$\frac{1}{2}$	1.25
216-10ST	56411	$\frac{3}{4}$	$\frac{3}{4}$	1.25

### Tuffy Angle Valves

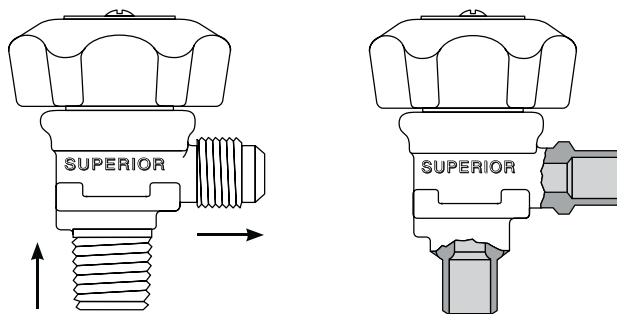

One directional flow

Part Number	IBCA Number	Size (Inches)		Weight (lbs.)
		Inlet	Outlet	
<b>Tuffy Angle</b>		NPT	x SAE	
114-4B	55906	$\frac{1}{4}$	$\frac{1}{4}$	0.50
114-6B	55909	$\frac{1}{4}$	$\frac{3}{8}$	0.50
<b>Tuffy Angle-Solder</b>		ODS	x ODS	
114-6S	55911	$\frac{3}{8}$	$\frac{3}{8}$	0.50
115-8S	55923	$\frac{1}{2}$	$\frac{1}{2}$	1.00

Tuffy Series Line Valves

Tuffy Series

Diaphragm Packless Line Valves

- Working pressure: 700 PSIG.
- Body construction: forged brass.
- Seat material: nylon.
- Diaphragm construction: stainless steel.
- Maximum temperature: 275° F.
- Minimum temperature: -40° F.
- UL® and cUL Listed, File No. SA3462(N).
- Valves may be installed without disassembly. Wrap body with damp cloth or other suitable heat sinking material during soldering.
- For use with CO<sub>2</sub>, CFC, HFC and HCFC refrigerants listed in CAN/CSA B52 and ANSI/ASHRAE 15 Section 9.2.
- For gases and liquids not listed, please consult factory.
- Spare Parts List on pp. 36-37.

Tuffy Charging Valves

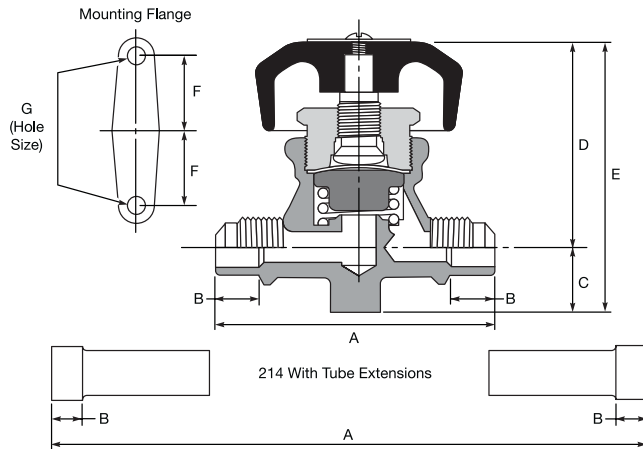

Part Number	Dimensions (Inches)							C <sub>v</sub>
	A	B	C	D	E	F	G	
214-4	2 <sup>3</sup> / <sub>4</sub>	—	1 <sup>9</sup> / <sub>32</sub>	1 <sup>29</sup> / <sub>32</sub>	2 <sup>1</sup> / <sub>2</sub>	3 <sup>1</sup> / <sub>4</sub>	0.199	N/A
214-6	2 <sup>3</sup> / <sub>4</sub>	—	1 <sup>9</sup> / <sub>32</sub>	1 <sup>29</sup> / <sub>32</sub>	2 <sup>1</sup> / <sub>2</sub>	3 <sup>1</sup> / <sub>4</sub>	0.199	0.882
215-8	3 <sup>3</sup> / <sub>8</sub>	—	1 <sup>3</sup> / <sub>16</sub>	2 <sup>9</sup> / <sub>16</sub>	3 <sup>3</sup> / <sub>8</sub>	7 <sup>1</sup> / <sub>8</sub>	0.199	1.788
216-10	3 <sup>3</sup> / <sub>8</sub>	—	1 <sup>3</sup> / <sub>16</sub>	2 <sup>9</sup> / <sub>16</sub>	3 <sup>3</sup> / <sub>8</sub>	7 <sup>1</sup> / <sub>8</sub>	0.199	2.828
214-4S	2 <sup>3</sup> / <sub>4</sub>	5 <sup>1</sup> / <sub>16</sub>	1 <sup>9</sup> / <sub>32</sub>	1 <sup>29</sup> / <sub>32</sub>	2 <sup>1</sup> / <sub>2</sub>	3 <sup>1</sup> / <sub>4</sub>	0.199	N/A
214-6S	2 <sup>3</sup> / <sub>4</sub>	7 <sup>1</sup> / <sub>16</sub>	1 <sup>9</sup> / <sub>32</sub>	1 <sup>29</sup> / <sub>32</sub>	2 <sup>1</sup> / <sub>2</sub>	3 <sup>1</sup> / <sub>4</sub>	0.199	0.882
215-8S	3 <sup>3</sup> / <sub>8</sub>	9 <sup>1</sup> / <sub>16</sub>	1 <sup>3</sup> / <sub>16</sub>	2 <sup>9</sup> / <sub>16</sub>	3 <sup>3</sup> / <sub>8</sub>	7 <sup>1</sup> / <sub>8</sub>	0.199	1.788
216-10S	3 <sup>3</sup> / <sub>8</sub>	2 <sup>1</sup> / <sub>32</sub>	1 <sup>3</sup> / <sub>16</sub>	2 <sup>9</sup> / <sub>16</sub>	3 <sup>3</sup> / <sub>8</sub>	7 <sup>1</sup> / <sub>8</sub>	0.199	2.828
214-4ST	6	5 <sup>1</sup> / <sub>16</sub>	1 <sup>9</sup> / <sub>32</sub>	1 <sup>29</sup> / <sub>32</sub>	2 <sup>1</sup> / <sub>2</sub>	3 <sup>1</sup> / <sub>4</sub>	0.199	N/A
214-6ST	5 <sup>1</sup> / <sub>8</sub>	7 <sup>1</sup> / <sub>16</sub>	1 <sup>9</sup> / <sub>32</sub>	1 <sup>29</sup> / <sub>32</sub>	2 <sup>1</sup> / <sub>2</sub>	3 <sup>1</sup> / <sub>4</sub>	0.199	0.882
215-8ST	6 <sup>1</sup> / <sub>16</sub>	9 <sup>1</sup> / <sub>16</sub>	1 <sup>3</sup> / <sub>16</sub>	2 <sup>9</sup> / <sub>16</sub>	3 <sup>3</sup> / <sub>8</sub>	7 <sup>1</sup> / <sub>8</sub>	0.199	1.788
216-10ST	7 <sup>1</sup> / <sub>16</sub>	2 <sup>1</sup> / <sub>32</sub>	1 <sup>3</sup> / <sub>16</sub>	2 <sup>9</sup> / <sub>16</sub>	3 <sup>3</sup> / <sub>8</sub>	7 <sup>1</sup> / <sub>8</sub>	0.199	2.828

Tuffy Angle Valves

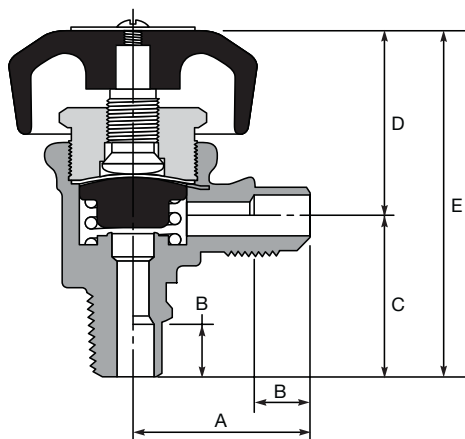

Part Number	Dimensions (Inches)							C <sub>v</sub>
	A	B	C	D	E	F	G	
114-4B	1 <sup>13</sup> / <sub>32</sub>	—	1 <sup>1</sup> / <sub>4</sub>	1 <sup>17</sup> / <sub>32</sub>	2 <sup>25</sup> / <sub>32</sub>	—	—	N/A
114-6B	1 <sup>13</sup> / <sub>32</sub>	—	1 <sup>1</sup> / <sub>4</sub>	1 <sup>17</sup> / <sub>32</sub>	2 <sup>25</sup> / <sub>32</sub>	—	—	0.450
114-6S	1 <sup>13</sup> / <sub>32</sub>	7 <sup>1</sup> / <sub>16</sub>	1 <sup>1</sup> / <sub>4</sub>	1 <sup>17</sup> / <sub>32</sub>	2 <sup>25</sup> / <sub>32</sub>	—	—	0.450
115-8S	1 <sup>13</sup> / <sub>16</sub>	9 <sup>1</sup> / <sub>16</sub>	1 <sup>3</sup> / <sub>8</sub>	2	3 <sup>3</sup> / <sub>8</sub>	—	—	2.542

## Tuffy Series

### Diaphragm Packless Line Valves

#### Tuffy X2 Line Valve with “Sealzall” Moisture Seal

“Sealzall” positive moisture seal prevents condensation from seeping down between the valve stem and bonnet, and eliminates valve “freeze-up.” Made of resilient Teflon®, the “Sealzall” moisture barrier is firmly sealed into the valve bonnet. It will not turn with the opening and closing of the valve, and will remain in position to provide a permanent moisture barrier.

#### Tuffy X7 Charging Valve

Same features of the standard Tuffy line but with brass housing on lower stem.

#### Tuffy Purge and Drain Valve

All the features of the standard Tuffy line. The flare cap and chain enable easy serviceability.

*Teflon is a registered trademark of Dupont.*

#### Tuffy X2 Line Valve with “Sealzall” Moisture Seal

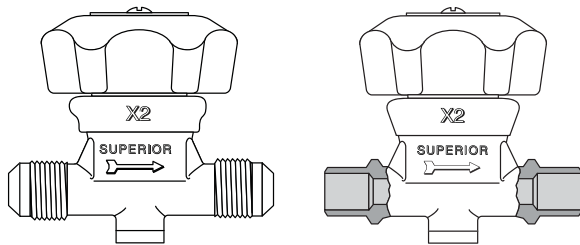

Part Number	IBCA Number	Size (Inches)			Weight (lbs.)
		Inlet	x	Outlet	
214X2-4	56389	SAE	x	SAE	0.50
214X2-4S	56390	1/4	x	1/4	0.50
214X2-6S	56392	3/8	x	3/8	0.50

#### Tuffy Charging Valves

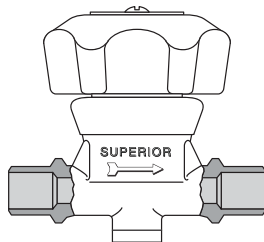

Part Number	IBCA Number	Size (Inches)			Weight (lbs.)
		Inlet	x	Outlet	
<b>Tuffy Charging Valves</b>		<b>ODS</b>	<b>x</b>	<b>ODS</b>	
214X7-4S	56396	1/4	x	1/4	0.50
216X7-10S	56416	3/8	x	3/8	0.50

#### Tuffy Purge and Drain Valves

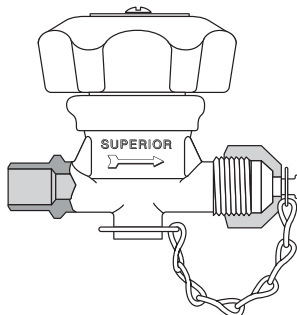

Part Number	IBCA Number	Size (Inches)			Weight (lbs.)
		Inlet	x	Outlet	
<b>Tuffy Purge and Drain</b>		<b>ODS</b>	<b>x</b>	<b>SAE</b>	
234A-4	56438	1/4	x	1/4	0.50
234A-6	56439	3/8	x	3/8	0.50

Tuffy Series Line Valves

Tuffy Series

Diaphragm Packless Line Valves

- Working pressure: 700 PSIG.
- Body construction: forged brass.
- Diaphragm construction: stainless steel.
- Maximum temperature: 275° F.
- Minimum temperature: -40° F.
- UL® and cUL Listed, File No. SA3462(N).
- Valves may be installed without disassembly. Wrap body with damp cloth or other suitable heat sinking material during soldering.
- For use with CO<sub>2</sub>, CFC, HFC and HCFC refrigerants listed in CAN/CSA B52 and ANSI/ASHRAE 15 Section 9.2.
- Spare Parts List on pp. 36–37.

Tuffy X2 Line Valve with “Sealall” Moisture Seal

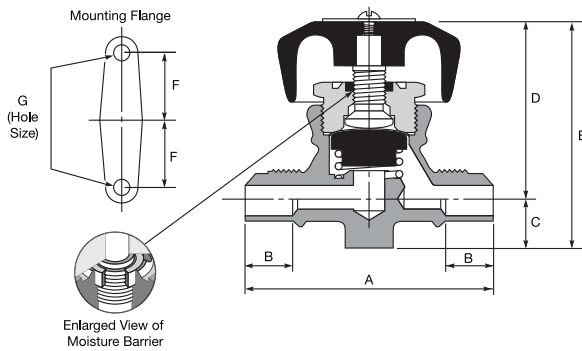

Part Number	Dimensions (Inches)							C <sub>v</sub>
	A	B	C	D	E	F	G	
214X2-4	2¾	—	1 <sup>9</sup> / <sub>32</sub>	1 <sup>29</sup> / <sub>32</sub>	2½	¾	0.199	N/A
214X2-4S	2¾	5/16	1 <sup>9</sup> / <sub>32</sub>	1 <sup>29</sup> / <sub>32</sub>	2½	¾	0.199	N/A
214X2-6S	2¾	7/16	1 <sup>9</sup> / <sub>32</sub>	1 <sup>29</sup> / <sub>32</sub>	2½	¾	0.199	0.882

Tuffy Charging Valves

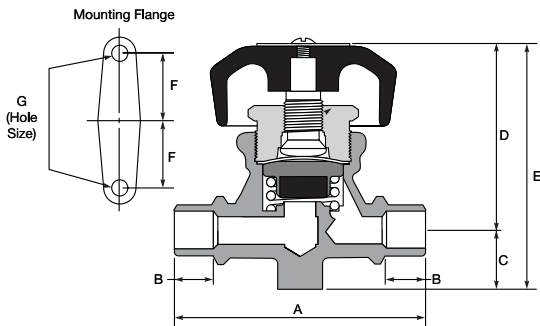

Part Number	Dimensions (Inches)							C <sub>v</sub>
	A	B	C	D	E	F	G	
<b>ODS x ODS</b>								
214X7-4S	2¾	5/16	1 <sup>9</sup> / <sub>32</sub>	1 <sup>29</sup> / <sub>32</sub>	2½	¾	0.199	N/A
216X7-10S	3¾	11/16	1 <sup>3</sup> / <sub>16</sub>	2 <sup>7</sup> / <sub>16</sub>	3¾	7/8	0.199	2.828

Tuffy Purge and Drain Valves

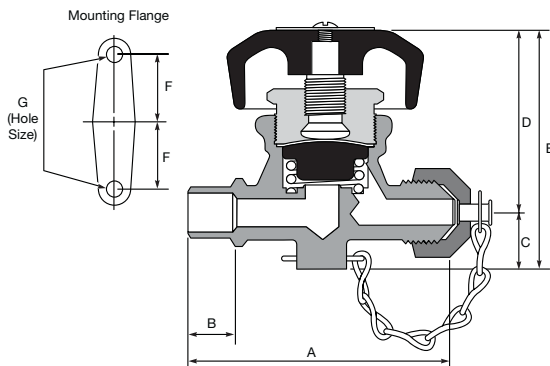

Part Number	Dimensions (Inches)							C <sub>v</sub>
	A	B	C	D	E	F	G	
234A-4	2¾	5/16	1 <sup>9</sup> / <sub>32</sub>	1 <sup>29</sup> / <sub>32</sub>	2½	¾	0.199	N/A
234A-6	2¾	7/16	1 <sup>9</sup> / <sub>32</sub>	1 <sup>29</sup> / <sub>32</sub>	2½	¾	0.199	0.882



## Horizontal or Vertical Installation Check Valves

### H-V Globe Check Valves

Globe Check Valves feature the time-proven piston construction simplified for easy reassembly after soldering. The improved "C" series with special non-metallic bonnet gaskets and Teflon® seat inserts permit the use of these valves in service temperatures as high as 400° F.

All H-V Globe Check Valves are constructed of all forged brass in the low pressure drop "Y" type design. Complete back pressure shutoff is achieved at low pressure.

*Note: Bolted bonnets are loosely assembled after testing to allow easy disassembly for soldering.*

*Teflon is a registered trademark of Dupont.*

### Line Check Valves

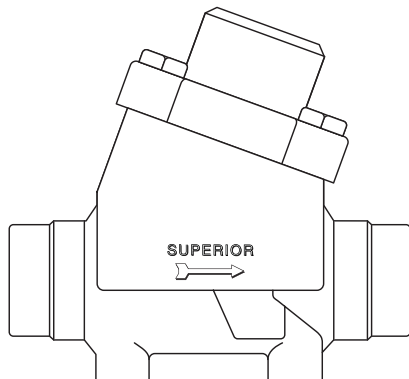

Part Number	IBCA Number	Size (Inches) ODS x ODS	Weight (lbs.)
<b>Line Valve Type</b>			
805C-14S	57348	7/8	2.50
806C-11S	57352	1 1/8	2.50
807C-13S	57336	1 3/8	5.00
808C-15S	57360	1 7/8	5.00
809C-21S	57364	2 1/8	12.75
884C-25S	57371	2 3/8	32.25
885C-31S	57372	3 1/8	32.25
886C-35S*	57373	3 7/8	37.00

\* Reduced port.

H-V Check Valves

Horizontal or Vertical Installation Check Valves

- Working pressure: up to 700 PSIG.
- Construction: all-forged brass.
- Seat material: Teflon®.
- Special non-metallic bonnet gasket.
- Service temperature up to 400° F.
- Low pressure drop “Y” design.
- Complete back-pressure shut-off at low pressure differential.
- Time-proven piston construction.
- Install in any position but upside down.
- UL® and cUL Recognized
- Recommended bolt torque for reassembly in chart below.
- For use with CO<sub>2</sub>, CFC, HFC and HCFC refrigerants listed in CAN/CSA B52 and ANSI/ASHRAE 15 Section 9.2.
- For gases and liquids not listed, please consult factory.
- Comes with standard ½-lb. differential spring.
- For special higher differential springs for all check valves, please consult factory.
- Suitable for many applications, such as hot gas defrost.
- Spare Parts List on pp. 36–37.

*Teflon is a registered trademark of Dupont.*

Line Check Valves

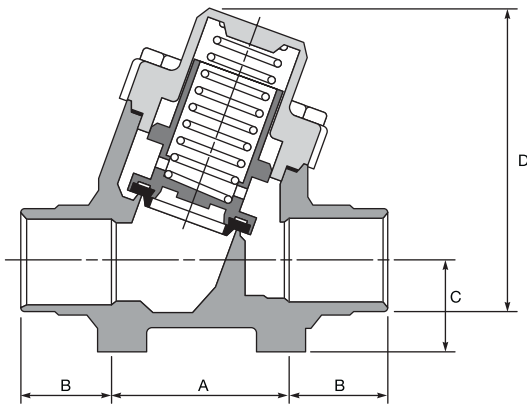

Part Number	Size	Dimensions (Inches)				Bolt Torques	
		A	B	C	D	(ft. lb.)	C <sub>v</sub>
805C-14S	7/8	1 13/16	15/16	3 1/32	3 19/32	12	10.60
806C-11S	1 1/8	1 11/16	1	3 1/32	3 19/32	12	12.36
807C-13S	1 3/8	2 1/8	1 1/16	1 1/16	4 1/16	30	21.67
808C-15S	1 5/8	2 3/8	1 1/16	1 1/16	4 1/16	30	23.63
809C-21S	2 1/8	3 3/8	1 1/2	1 11/16	5 7/8	50	42.00
884C-25S	2 3/8	5 1/8	1 7/8	2 1/8	7 3/4	70	82.30
885C-31S	3 1/8	5 5/8	1 7/8	2 1/8	7 3/4	70	91.30
886C-35S	3 3/8	5 5/8	1 7/8	2 1/8	7 3/4	70	91.00

## Horizontal or Vertical Installation Check Valves

### Type 802B Check Valves Series

(Patent 3,438,391)

For years, this “Y” type of valve has been the most popular design in the refrigeration industry. The internal parts can easily be removed and reassembled after soldering. This basic “Y” type design reduces pressure drop to a very low level.

The Teflon® seat insert rapidly conforms to the cone style of seating surface in the body. This ensures positive shut-off characteristics. This valve minimizes leakage even at the lowest back pressure. A specially designed secondary seat backs up the primary seat. After approximately 10,000 cycles of operation, the secondary seat becomes effective. This is done to ensure even better shut-off characteristics as the valve wears into service.

Upon reassembly of the valve, positive shut-off between the body cap and the body is assured by means of a special gasket seal.

All Superior H-V Check Valves have Teflon seats. These valves may be installed in any position, except upside down.

*Teflon is a registered trademark of Dupont.*

### Type 802B Check Valve Series

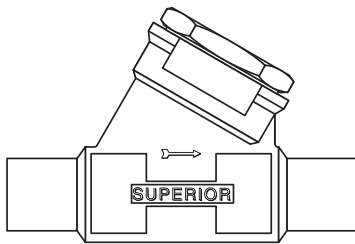

Part Number	IBCA Number	Size (Inches)	Weight (lbs.)
<b>Flare x Flare</b>			
802B-4	57328	¼	0.50
802B-6	57331	⅜	0.50
802B-8	57334	½	0.50
<b>ODS x ODS</b>			
802B-4S	57329	¼	0.50
802B-6S	57332	⅜	0.50
802B-8S	57335	½	0.50
803B-10S	57340	⅝	0.50
804A-14S	57344	⅞	1.00

### Type 802B Check Valve Series ODS x ODS Tube Extensions\*

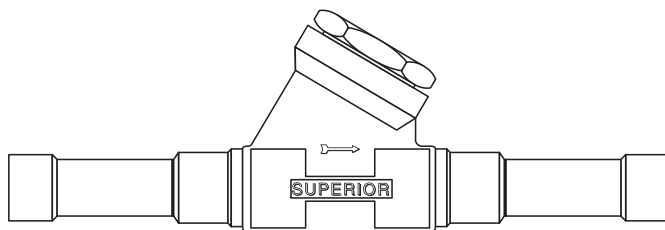

Part Number	IBCA Number	Size (Inches)	Weight (lbs.)
802B-4ST	57330	¼	0.50
802B-6ST	57333	⅜	0.50
802B-8ST	57336	½	0.75
803B-10ST	57341	⅝	0.75
804A-14ST	57345	⅞	1.00

\* Tube extensions permit valve to be silver soldered directly to line without disassembly.

## Horizontal or Vertical Installation Check Valves

- Working pressure: up to 700 PSIG.
- Construction: all-forged brass.
- Seat material: Teflon®.
- Specially designed secondary seat backs up primary seat.
- Copper gasket between body cap and body assures positive shut-off.
- Minimum temperature: -40° F.
- Maximum temperature: 400° F.
- Low pressure drop “Y” design.
- Tube extensions permit valve to be soldered without disassembly.
- All UL® and cUL Recognized, File No. SA2989(N).
- Patent No. 3,438,391.
- Recommended bonnet torque: 802/803—45 ft. lbs., 804—75 ft. lbs.
- For use with CO<sub>2</sub>, CFC, HFC and HCFC refrigerants listed in CAN/CSA B52 and ANSI/ASHRAE 15 Section 9.2.
- Suitable for many applications, such as hot gas defrost.
- For gases and liquids not listed, please consult factory.
- Comes with standard 1/2-lb. differential spring.
- For special higher differential springs for all check valves, please consult factory.
- Spare Parts List on pp. 36–37.

*Teflon is a registered trademark of Dupont.*

### Type 802B Check Valve Series

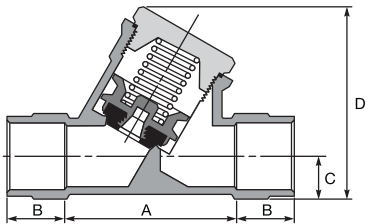

Part Number	Size	Dimensions (Inches)				C <sub>v</sub>
		A	B	C	D	
<b>Flare x Flare</b>						
802B-4	1/4	2	1/2	15/32	2 1/16	N/A
802B-6	3/8	1 1/4	3/8	15/32	2 1/16	1.75
802B-8	1/2	1 1/2	3/4	15/32	2 1/16	3.2
<b>ODS x ODS</b>						
802B-4S	1/4	2 3/8	3/16	15/32	2 1/16	N/A
802B-6S	3/8	2 1/8	7/16	15/32	2 1/16	1.75
802B-8S	1/2	1 7/8	9/16	15/32	2 1/16	3.2
803B-10S	3/8	2	2 1/32	15/32	2 1/16	3.8
804A-14S	7/8	2 1/4	3/4	19/32	2 7/16	8.5

### Type 802B Check Valve Series

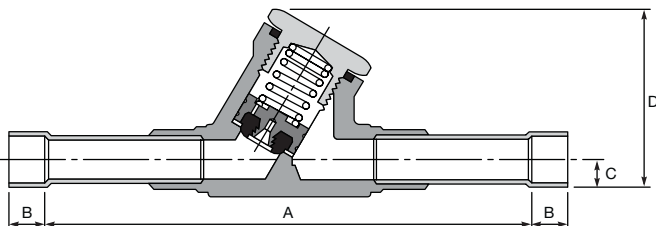

Part Number	Size	Dimensions (Inches)				C <sub>v</sub>
		A	B	C	D	
802B-4ST	1/4	5 5/8	3/16	15/32	2 1/16	N/A
802B-6ST	3/8	5 3/8	3/8	15/32	2 1/16	1.75
802B-8ST	1/2	5 3/16	3/8	15/32	2 1/16	3.2
803B-10ST	3/8	5 1 3/16	1/2	15/32	2 1/16	3.8
804A-14ST	7/8	6 1/4	3/4	19/32	2 7/16	8.5



## Horizontal or Vertical Installation Check Valves

### Type 804ADX Check Valves Series

This unique dashpot cylinder design is ideal for compressor discharge applications. The tight tolerance fit between the seat guide and the seal cap bore acts like a shock absorber to dampen the seat from rapid compressor palpitations.

- Working pressure: 700 PSIG.
- Construction: forged brass.
- Seat material: Teflon®.
- Specifically designed secondary seat backs up primary seat.
- Copper gasket between body cap and body assures positive shut-off.
- Minimum temperature: -40° F.
- Maximum temperature: 400° F.
- Low pressure drop “Y” design.
- Stainless steel spring.
- UL® and cUL Recognized, File No. SA2989(N).
- For use with CO<sub>2</sub>, CFC, HFC and HCFC refrigerants listed in CAN/CSA B52 and ANSI/ASHRAE 15 Section 9.2.
- For gases and liquids not listed, please consult factory.

*Teflon is a registered trademark of Dupont.*

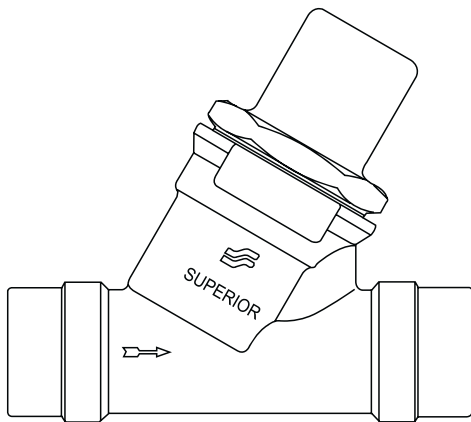

Part Number	IBCA Number	Size (Inches)
804ADX11-14S	21976	7/8
804ADX12-14S*	26586	7/8

\* Teflon disc in bottom of seal cap for additional noise dampening.

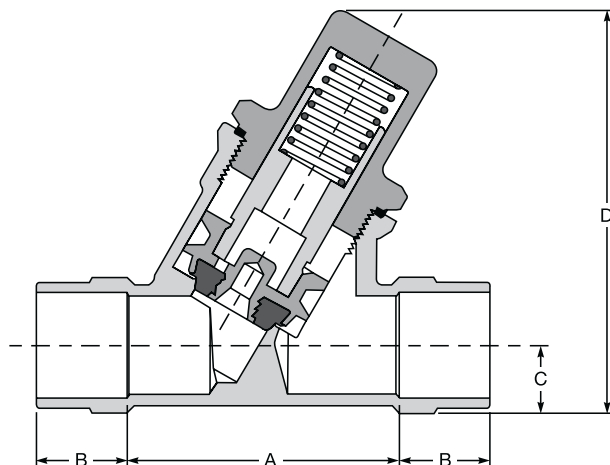

Part Number	Dimensions (Inches)				
	Size	A	B	C	D
804ADX11-14S	7/8	2 1/4	3/4	19/32	3.33
804ADX12-14S*	7/8	2 1/4	3/4	19/32	3.33

\* Teflon disc in bottom of seal cap for additional noise dampening.

In-Line Magnetic Check Valves

**900MA Series**  
In-Line Check Valve

- Copper connection sizes 3/8" through 2 1/2".
- Hermetically sealed spun copper body.
- Thirty-mesh screen to protect seat surface from debris.
- Temperature range: -40° F up to 300° F
- Full range of sizes.
- Magnetic actuation.
- Arrow indicates direction of flow.
- Can be installed in any position.
- Minimal pressure drop.
- UL® and cUL Recognized, File No. SA2989(N).
- For use with CO<sub>2</sub>, CFC, HFC and HCFC refrigerants listed in CAN/CSA B52 and ANSI/ASHRAE 15 Section 9.2.
- Proprietary seat design minimizes leaks.

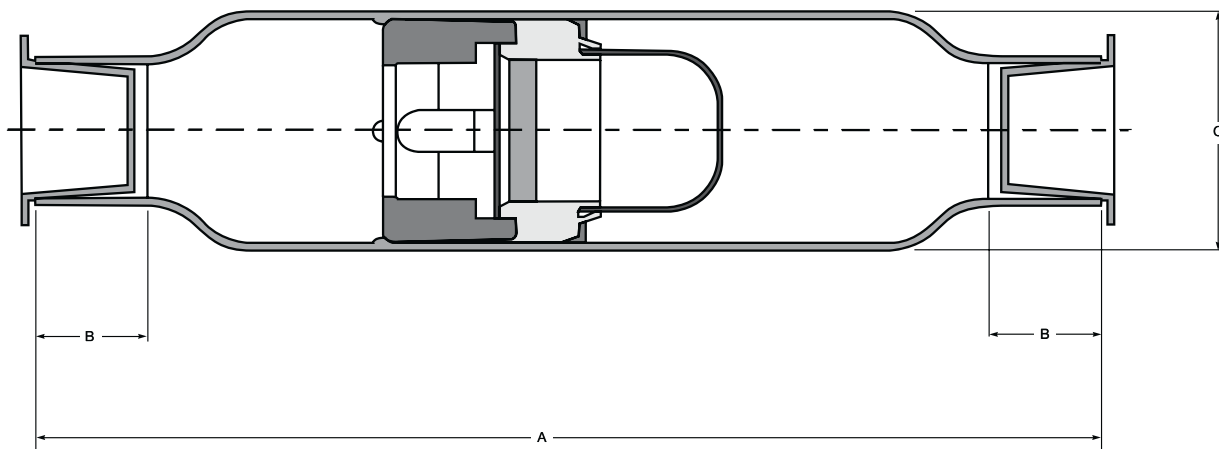

Part Number	IBCA No.	Connection		A ± .125	B ± .030	C	Opening Pressure oz./sq. in.	MWP (PSIG)	Burst Pressure (PSIG)	Leak Rate CIM @ 60 psi	Nominal Tons R22 Suction 40° @ 1 psi	Nominal Tons R22 Liquid 40° @ 1 psi	Weight (lbs.)
		(ODS)	Cup Size										
900MA-6S	25694	3/8	0.378/0.381	4.00	0.31	0.875	1.3	800	4000	<0.015	0.6	3.1	.22
900MA-8S	25693	1/2	0.503/0.506	5.00	0.38	1.125	3.5	760	3800	<0.034	1.2	9.4	.22
900MA-10S	25692	5/8	0.628/0.631	5.00	0.50	1.125	3.5	760	3800	<0.034	1.4	13	.38
900MA-14S	25690	7/8	0.878/0.881	7.00	0.75	1.625	3.8	700	3000	<0.074	3.7	29	.40
900MA-11S	25689	1 1/8	1.128/1.132	8.38	0.94	2.125	6.8	700	3000	<0.122	6.0	51	1.66
900MA-13S	25688	1 3/8	1.378/1.382	9.38	1.00	2.625	10.2	700	2900	<0.172	9.5	79	2.6
900MA-15S	25687	1 5/8	1.628/1.633	10.50	1.09	3.125	11.4	700	2900	<0.272	17.0	102	3.8
900MA-21S	25686	2 1/8	2.128/ 2.133	12.00	1.34	3.625	18.1	700	2500	<0.386	30.0	213	5.5
900MA-25S	25685	2 3/8	2.628/2.633	13.00	1.50	4.125	23.0	700	2300	<0.512	50.0	375	7.8

### 3155W Series

**INTEGRA-SEAL®**

The 3155W Series Dual Pressure-Relief Valve Series is a next-generation product incorporating Superior's proven **INTEGRA-SEAL®** welded ball valve technology to further safeguard your system in the event of a pressure relief valve discharge.

This product provides you with the ability to maintain protection of your system with a back-up pressure relief valve while enabling you to replace the other relief valve — all without dropping system pressure!

The Dual Pressure-Relief Valve Series ball valves employ the latest robotic welding technology, and the valves have full-size ports for unrestricted

flow. Every continuous welded body joint is 100% factory tested to ensure positive leak-free performance.

Dual Teflon® ball seals surround a polished brass ball at each end. A secondary seal becomes effective if foreign material scores the primary seal — even unfavorable conditions such as compressor burnout — a Superior exclusive.

The 3155W Series Dual Pressure-Relief Valve assembly is constructed using an all-forged brass body. High flow internals maximize flow capacity, another Superior exclusive. The stem and cap of the Series 3155W is located on the side of the valve to provide

easy access with a wrench. Our time-tested seal cap design permits valve operation without seal cap removal, and stamped flow direction indicators on the seal cap indicate pressurized port at a glance. Mechanical internal machined stops ensure positive open or closed seal position with only a ¼ turn.

The Series 3155W incorporates a dual stem seal design utilizing Teflon packing compressed by an internal packing nut, forming the primary seal. The unique seal cap design permits valve operation without removal of the seal cap and uses Teflon gaskets to provide a secondary seal — a third Superior exclusive. There are no synthetic O-rings.

*Teflon is a registered trademark of Dupont.*

#### Series 3155W

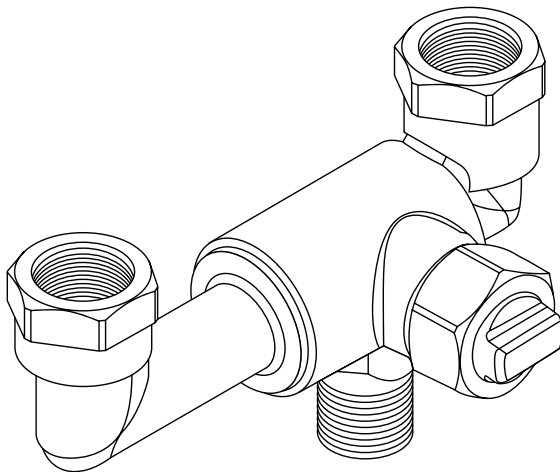

Part Number	IBCA Number	Inlet Connection	Outlet Connection	Size (Inches)	
				Ball Port Diameter	Weight (lbs.)
3155W-D	59526	½ MPT	½ FPT	0.563 (14.30 mm)	1.5
3155W-E	60276	¾ MPT	¾ FPT	0.750 (19.05 mm)	3.2
3155WX1-14S	60185	¾ ODM	½ FPT	0.563 (14.30 mm)	1.5

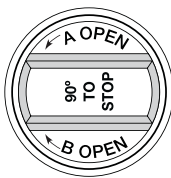

#### Seal Cap

Exclusive Seal Cap design permits operation of valve without removal. Markings on cap top designate at-a-glance pressurized port.

# Dual Pressure-Relief Valve Assembly

## 3155W Series

- High flow internals for maximum flow capacity. A Superior exclusive!
- **INTEGRA-SEAL**® welded ball valve design allows removal or replacement of either relief valve while system is still pressurized without loss of charge!
- Proven seal cap and stem design. No synthetic O-ring seal. Cap design permits valve operation without seal cap removal.
- The male inlet connection enables easy installation onto receiver. No need for male adapters!
- Flow direction indicator on seal cap. Mechanical internal machined stops ensure positive open or closed seal position. Full open or close with only a ¼ turn.
- Dual Teflon® ball seals at each end. The secondary seal becomes effective if foreign material scores the primary seal — another Superior exclusive!
- Every valve is 100% factory sealed and leak tested.
- Full refrigeration service temperature range of -40° F to +325° F (-40° C to +163° C). Design working pressure of 700 PSIG.
- All-forged brass body and polished brass ball.
- UL® and cUL Listed, File No. 3462 (N).
- For use with CO<sub>2</sub>, CFC, HFC and HCFC refrigerants listed in CAN/CSA B52 and ANSI/ASHRAE 15 Section 9.2.
- For gases or liquids not listed, please consult factory.
- US Patent No. 5,671,911.

*Teflon is a registered trademark of Dupont.*

### 3155W Series

Part Number	Dimensions (Inches)			C <sub>v</sub> Port	
	C	D	E	Outlet A	Outlet B
3155W-D	4.69 (119.12mm)	3.350 (85.09mm)	1.26 (31.93mm)	5.629	5.556
3155W-E	5.31 (134.87mm)	3.90 (99.06mm)	1.49 (37.85mm)	10.20	10.35
3155WX1-14S	4.69 (119.12mm)	3.350 (85.09mm)	1.26 (31.93mm)	5.629	5.556

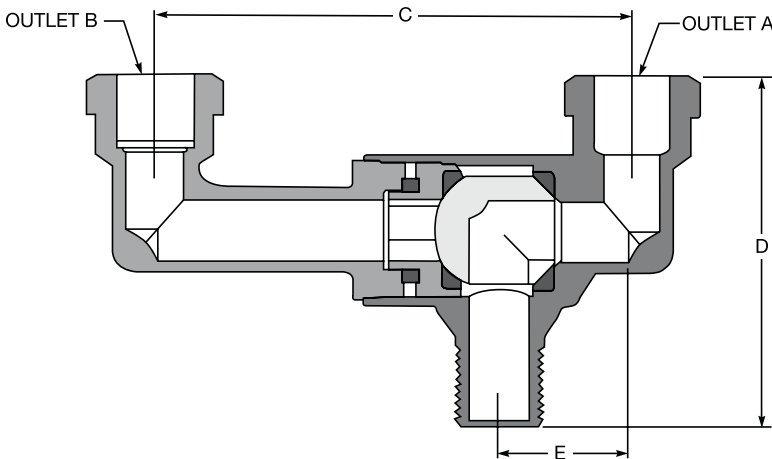

#### Use 3155W-D with Superior Relief Valves

Part Number 3020	½" MPT x ½" FPT	MPT x ⅝" SAE
Part Number 3220	½" MPT x ½" FPT	MPT x ⅝" SAE Angle
Part Number 3030	½" MPT x ½" FPT	
Part Number 3031	½" MPT x ¾" FPT	

#### Use 3155W-E with Superior Relief Valves

Part Number 3045	¾" MPT x ¾" FPT	
------------------	-----------------	--

#### Use 3155WX1-14S with Superior Relief Valves

Part Number 3020	½" MPT x ½" FPT	MPT x ⅝" SAE
Part Number 3220	½" MPT x ½" FPT	MPT x ⅝" SAE Angle
Part Number 3030	½" MPT x ½" FPT	
Part Number 3031	½" MPT x ¾" FPT	

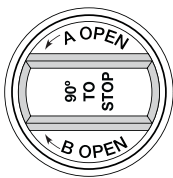

#### Seal Cap

Exclusive Seal Cap design permits operation of valve without removal. Markings on cap top designate at-a-glance pressurized port.



## Pressure-Relief Valves

Superior offers the most complete range of refrigeration relief valves in the industry. All valves have been designed, constructed and rated in accordance with ANSI/ASHRAE 15-1994 Standard Safety Code for Mechanical Refrigeration.

Each valve is stamped U.V./N.B. to indicate National Board certifications as to capacities. Certified National Board ratings are printed on the next page.

Minimum setting for all relief valves listed is 150 psi. These pressure-relief valves are all Teflon® seated, permitting their use in applications of either high or low temperatures where the

conventional rubber seated valves are often completely unsatisfactory.

Part Numbers indicate style and size of relief valve only — customer must specify pressure setting when ordering. **Standard pressure settings are available from 150-800 psi. Part Numbers for pressure settings 500-800 include a “C” as in “3000C-550”**

*Note: Prior to installation or during pressure vessel testing, Superior pressure-relief valves should not be discharged. Any dirt in the system may embed in the seat and prevent the pressure-relief valve from resealing properly.*

*Important: A pressure-relief valve is installed in a refrigeration system primarily to protect the receiver. Since it is not intended to be an overload or high-pressure cutout, we recommend that the pressure-relief valve be set at the working pressure marked on the receiver, regardless of the type of refrigerant used. The method for determining “set pressure” is outlined in ANSI/ASHRAE 15 Standard Safety Code for Mechanical Refrigeration.*

*Note: Pressure-relief valves cannot be returned to the factory. This policy helps maintain product integrity.*

*Teflon is a registered trademark of Dupont.*

### Atmospheric — Types 3000 & 3000C, 3001 & 3001C, 3002 & 3002C

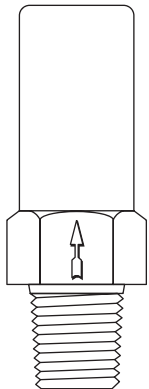

Part Number	Port Diameter	Size (Inches)		Weight (lbs.)	Weight (lbs.) C
		Inlet	Outlet		
NPT x					
3000	3/16	1/8	*	0.19	0.21
3001	3/16	1/4	*	0.19	0.21
3002	3/16	3/8	*	0.19	0.21

\* Atmospheric — No external connection.

RoHS compliant

### Angle — Types 3212 & 3212C, 3214 & 3214C, 3215 & 3215C, 3216 & 3216C, 3220 & 3220C

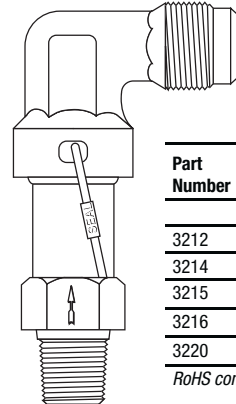

Part Number	Port Diameter	Size (Inches)			Weight (lbs.)	Weight (lbs.) C
		Inlet	Outlet	x SAE		
NPT x SAE						
3212	3/16	1/4	3/8	0.50	0.52	
3214	3/16	3/8	3/8	0.50	0.52	
3215	3/16	3/8	1/2	0.50	0.52	
3216	9/32	3/8	1/2	0.75	0.83	
3220	9/32	1/2	3/8	0.75	0.83	

RoHS compliant

### Straight-Thru — Types 3012 & 3012C, 3014 & 3014C, 3015 & 3015C, 3016 & 3016C, 3020 & 3020C

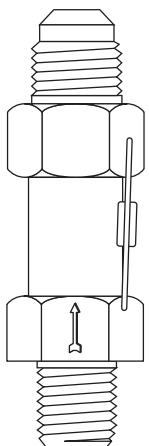

Part Number	Port Diameter	Size (Inches)			Weight (lbs.)	Weight (lbs.) C
		Inlet	Outlet	SAE		
NPT x SAE						
3012	3/16	1/4	3/8	0.25	0.27	
3014	3/16	3/8	3/8	0.25	0.27	
3015	3/16	3/8	1/2	0.25	0.27	
3016	9/32	3/8	1/2	0.50	0.58	
3020	9/32	1/2	3/8	0.50	0.58	

RoHS compliant

### Female Connection — Types 3030, 3031, 3045, 3060 & 3075

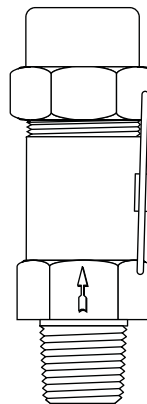

Part Number	Port Diameter	Size (Inches)			Weight (lbs.)	Weight (lbs.) C
		Inlet	Outlet	FPT		
NPT x FPT						
3030	7/16	1/2	1/2	0.75	0.83	
3031	7/16	1/2	3/4	0.75	0.83	
3045	7/16	3/4	3/4	0.75	0.83	
3060	23/32	1	1	2.50	2.58	
3075	23/32	1 1/4	1 1/4	2.75	2.83	

RoHS compliant

Pressure-Relief Valves

Pressure-Relief Valves

- Minimum setting: 150 PSIG.
- Body construction: brass.
- Seat material: 100% Teflon®.
- Spring material: stainless steel.
- Minimum temperature: -40° F.
- Maximum temperature: 325° F.
- Initial leak: set pressure ±3%.
- Full discharge: initial leak +10%.
- Reseat: by 80% of set pressure.
- ASME Certificate No.: 28,516.
- Canadian Registration No.: 0G8195.
- RoHS compliant.
- N.B. Certificate Nos.:
  - 3000 Series M54009
  - 3020 Series M54010
  - 3030 Series M54021
  - 3060 Series M54032

Teflon is a registered trademark of Dupont.

Discharge capacities shown in pounds air per minute.

To convert pounds air per minute to standard cubic feet per minute, multiply by 13.1.

Atmospheric —

Types 3000 & 3000C, 3001 & 3001C, 3002 & 3002C

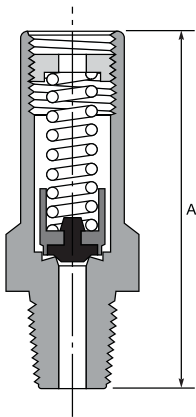

Pressure Setting	Discharge Capacity
<i>Part Numbers 3000, 3001, 3002</i>	
235	8.1
300	10.2
350	11.8
400	13.5
425	14.3
450	15.1
500	16.7
<i>Part Numbers 3000C, 3001C, 3002C</i>	
550	18.3
600	19.9
650	21.6
700	23.2
750	24.9
800	26.5

Part Number	Dimensions (Inches)	
	A	
<i>Settings</i>	150 to 500 psi (10.34 to 34.47 bar)	
3000	2.17	
3001	2.30	
3002	2.30	
<i>Settings</i>	501 to 600 psi (34.54 to 41.37 bar)	601 to 800 psi (41.44 to 55.16 bar)
3000C	2.17	2.42
3001C	2.30	2.55
3002C	2.30	2.55

Note: For IBCA numbers, consult factory

Angle —

Types 3212 & 3212C, 3214 & 3214C, 3215 & 3215C, 3216 & 3216C, 3220 & 3220C

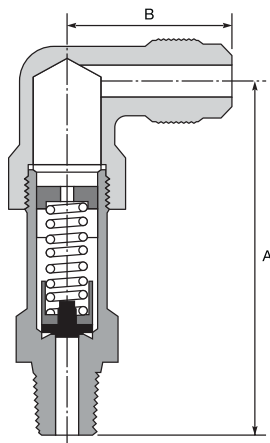

Pressure Setting	Discharge Capacity	
<i>Part Numbers 3212, 3214, 3215, 3216, 3220</i>		
	<b>3212, 3214, 3215</b>	<b>3216, 3220</b>
235	8.1	16.1
300	10.2	20.3
350	11.8	23.6
400	13.5	26.8
425	14.3	28.4
450	15.1	30.1
500	16.7	33.3
<i>Part Numbers 3212C, 3214C, 3215C, 3216C, 3220C</i>		
	<b>3212C, 3214C, 3215C</b>	<b>3216C, 3220C</b>
550	18.3	36.6
600	19.9	39.9
650	21.6	43.1
700	23.2	46.4
750	24.9	49.6
800	26.5	52.9

Part Number	Dimensions (Inches)			
	A		B	
<i>Settings</i>	150 to 500 psi (10.34 to 34.47 bar)			
3212	2.92		1.41	
3214	2.92		1.41	
3215	2.92		1.41	
3216	2.66		1.50	
3220	2.84		1.62	
<i>Settings</i>	501 to 600 psi (34.54 to 41.37 bar)		601 to 800 psi (41.44 to 55.16 bar)	
3212C	2.92	1.41	3.32	1.41
3214C	2.92	1.41	3.32	1.41
3215C	2.92	1.41	3.32	1.41
<i>Settings</i>	501 to 800 psi (34.54 to 55.16 bar)			
3216C	3.60		1.50	
3220C	3.80		1.62	

## Pressure-Relief Valves

### Straight-Thru –

Types 3012 & 3012C, 3014 & 3014C, 3015 & 3015C, 3016 & 3016C, 3020 & 3020C

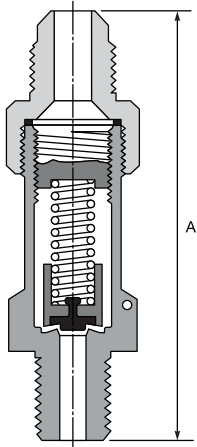

Pressure Setting	Discharge Capacity	
	3012, 3014, 3015	3016, 3020
<i>Part Numbers 3012, 3014, 3015, 3016, 3020</i>		
235	8.1	16.1
300	10.2	20.3
350	11.8	23.6
400	13.5	26.8
425	14.3	28.4
450	15.1	30.1
500	16.7	33.3
<i>Part Numbers 3012C, 3014C, 3015C, 3016C, 3020C</i>		
	3012C, 3014C, 3015C	3016C, 3020C
550	18.3	36.6
600	19.9	39.9
650	21.6	43.1
700	23.2	46.4
750	24.9	49.6
800	26.5	52.9

Part Number	Dimensions (Inches)	
	A	
<i>Settings</i>	<i>150 to 500 psi (10.34 to 34.47 bar)</i>	
3012	2.98	
3014	2.98	
3015	3.11	
3016	3.28	
3020	3.50	
<i>Settings</i>	<i>501 to 600 psi (34.54 to 41.37 bar)</i>	<i>601 to 800 psi (41.44 to 55.16 bar)</i>
3012C	2.98	3.35
3014C	2.98	3.35
3015C	3.11	3.47
<i>Settings</i>	<i>501 to 800 psi (34.54 to 55.16 bar)</i>	
3016C	4.13	
3020C	4.45	

### Female Connection –

Types 3030, 3031, 3045, 3060, 3075\*

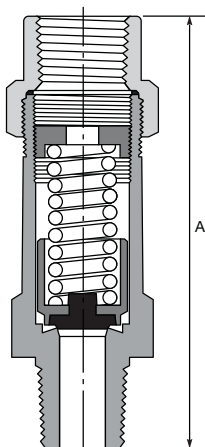

Pressure Setting	Discharge Capacity	
	3030, 3045	3060, 3075
235	36.9	88.0
300	46.6	111.0
350	54.0	*
400	61.4	*
425	65.1	*
450	68.8	*

\* Not available at pressure settings above 300 psi.

Part Number	Dimensions (Inches)	
	A	
3030	3.69	
3031	4.00	
3045	4.00	
3060	4.87	
3075	5.12	

## Selection of Relief Valves for Commercial Refrigeration and Air Conditioning Applications Based on ANSI/ASHRAE Standard 15

To select a pressure-relief valve, it is necessary first to determine the discharge capacity required to protect the refrigerant-containing vessel under consideration. The ANSI/ASHRAE Standard 15 states that the required discharge capacity of a pressure-relief valve used on such a vessel is directly proportional to the size of the vessel. Once the size of the vessel to be protected is known, the required discharge capacity of the pressure-relief valve may then be determined by using the following formula:

$$C=fDL$$

- Where: C = minimum required discharge capacity of the pressure-relief device in pounds of air per minute (kg/sec).  
 f = factor dependent upon type of refrigerant<sup>1</sup>. (See Table 1 below)  
 D = outside diameter of vessel in feet (m).  
 L = length of vessel in ft. (m).

**Table 1**

<b>Refrigerant</b> .....	<b>Value of f</b>
<i>When used on the low side of a limited-charge cascade system (Values in parentheses are metric):</i>	
R-23, R-170, R-744, R-1150, R-508A, R-508B .....	1.0 (0.082)
R-13, R-13B1, R-503 .....	2.0 (0.163)
R-14 .....	2.5 (0.203)
<i>Other applications:</i>	
R-718 .....	0.2 (0.016)
R-717 .....	0.5 (0.041)
R-11, R-32, R-113, R-123, R-142b, R-152a, R-290, R-600, R-600a, R-764 .....	1.0 (0.082)
R-12, R-22, R-114, R-124, R-134a, R-401A, R-401B, R-401C, R-405A, R-406A, R-407C, R-407D, R-407E, R-409A, R-409B, R-411A, R-411B, R-411C, R-412A, R-414A, R-414B, R-500, R-1270 .....	1.6 (0.131)
R-143a, R-402B, R-403A .....	2.0 (0.163)
R-407A, R-408A, R-413A .....	2.0 (0.163)
R-115, R-402A, R-403B, R-404A, R-407B, R-410A, R-410B, R-502, R-507A, R-509A .....	2.5 (0.203)

Example: What is the required discharge capacity of a pressure-relief valve to be used on an R-22 receiver that is 14" in diameter and 42" long having a design working pressure of 320 psi?

Solution: D = 1.167 ft., L = 3.5 ft., and f = 1.6 from Table 1:  
 C = fDL = 1.6 x 1.167 x 3.5  
 C = 6.5 lbs. air/min.

In other words, under the conditions listed above, a receiver of this size requires a pressure-relief valve with a minimum discharge capacity of 6.5 pounds of air per minute at a pressure setting of 320 PSIG.

### Pressure-Relief Valve Settings

All pressure-relief valves are rated according to their discharge capacity either in pounds of air per minute or kg/sec. at a given pressure setting. Under the ANSI/ASHRAE 15 Standard, pressure-relief valves shall start to function at a pressure not to exceed the design pressure of the parts of the system protected.

Generally, a pressure-relief valve may be set so that its initial leak is 100% of the design working pressure of the pressure vessel, regardless of the type of refrigerant used. The method of determining set pressure is outlined in Section 9.2 of the ANSI/ASHRAE Standard 15.

Sherwood manufactures pressure-relief valves in standard settings of 235, 300, 350, 400, 425 and 450 PSIG. Relief valves with settings other than standard may be ordered from the factory at a slight additional cost.

### Capacity of Pressure-Relief Valves

Flow capacities of Superior pressure-relief valves are expressed in either pounds of air per minute or standard cubic feet per minute. To convert pounds of air per minute to standard cubic feet per minute, multiply by 13.1.

To determine the pressure-relief valve capacities at any pressure setting between 150 and 450 PSIG, use the following formula:

$$C = S(1.1P+14.7)$$

- Where: C = Pressure-relief valve capacity in pounds of air per minute  
 P = Pressure setting of relief valve in PSIG  
 S = Pressure-relief valve flow factor

Values of "S" flow factor for each pressure-relief valve series are given in Table 2. Table 2 (pg. 23) gives the certified flow ratings in pounds of air per minute for all of the pressure-relief valve series at the standard pressure settings.

**Table 2**

CERTIFIED FLOW RATINGS — for standard settings

Flow capacity as determined by the National Board of Boiler and Pressure Vessel Inspectors in accordance with A.S.M.E. Code, Section VIII, Division 1, and as required by ANSI/ASHRAE Standard 15: Safety Code For Mechanical Refrigeration.

Series	3000		3020	3030	3060
Flow Factor "S"	0.0296		0.059	0.135	0.322
Part Number	3000, 3000C	3015, 3015C	3016, 3016C	3030	3060
	3001, 3001C	3212, 3212C	3020, 3020C	3031	3075
	3002, 3002C	3214, 3214C	3216, 3216C	3045	
	3012, 3012C	3215, 3215C	3220, 3220C		
	3014, 3014C				

Example: What is the flow capacity of a Sherwood 3045 pressure-relief valve set to 350 PSIG?

Solution: Referring to Table 2, we find that a 3045 pressure-relief valve is part of the 3030A Series and that its flow capacity is 54.0 lbs. air/min. The calculation goes as follows:

"S" factor from Table 2 for the 3030A Series is 0.135. Therefore:

$$C = S(1.1P + 14.7) = 0.135 \times [(1.1) \times 350 + 14.7]$$

$$C = 54.0 \text{ lbs. air/min.}$$

To convert 54.0 lbs. air/min. to SCFM:

$$C = 54.0 \times 13.1 = 707.4 \text{ SCFM}$$

As you will note from Table 2, the higher the set pressure, the greater the flow capacity of the pressure-relief valve.

**General Regulations and Recommendations**

1. Pressure-relief valves are installed in a refrigeration system primarily to protect the receiver or other pressure vessel in the event of a fire or any other emergency high-pressure conditions. Fuse plugs protect only in the event of fire.
2. All systems must have a pressure-relief valve or a fuse plug installed in order to comply with the ANSI/ASHRAE Standard 15.
3. Pressure vessels with an internal gross volume of 3 ft.<sup>3</sup> (0.085 m<sup>3</sup>) or less shall use one or more pressure-relief devices or a fusible plug.  
*Note: Local codes may require pressure-relief valves on receivers smaller than 3 ft.<sup>3</sup>.*
4. Pressure vessels of more than 3 ft.<sup>3</sup> (0.085 m<sup>3</sup>) but less than 10 ft.<sup>3</sup> (0.285 m<sup>3</sup>) internal gross volume shall use one or more pressure-relief devices. Fusible plugs are not permitted and should not be used.

5. Pressure vessels of 10 ft.<sup>3</sup> (0.285 m<sup>3</sup>) or more internal gross volume use a single rupture member or dual pressure-relief valves when discharging to the atmosphere. Dual pressure-relief valves are installed with a three-way valve to allow testing or repairs (See Sherwood 3155W Series Valves). A three-way valve used in conjunction with the dual pressure-relief valves is not considered a stop valve.
6. Fuse plugs are temperature responsive relief devices only, and for all practical purposes, can only be considered as protection for the receiver of the system in cases of fire when the fire is in the immediate vicinity of the fuse plug.
7. Sherwood recommends the use of spring-loaded pressure-relief devices, such as our four series of pressure-relief valves. They are pressure sensitive and add an additional protection against abnormal system pressures.
8. Sherwood pressure-relief valves are approved and tested as required by Section VIII, Division 1 of the ASME Boiler and Pressure Vessel Code. All valves have pertinent data marked on the side of the valve body as required by the ASME Boiler and Pressure Vessel Code.
9. The pressure-relief valve set pressure cannot be higher than the design working pressure of the pressure vessel it is protecting, but, if conditions permit, the pressure-relief valve set pressure should be at least 25% higher than the maximum normal operating pressure.
10. All pressure-relief valves installed on the high side must be in a vapor space as near to the receiver as practical. Stop valves cannot be placed in the line between the pressure-relief valve and the pressure vessel it is protecting. In general, the pressure-relief valve should be installed directly to the receiver above the liquid level or as near to the inlet of the receiver as practical. All pipe and fittings between the pressure-relief valve and the parts of the system it protects must have at least the same diameter of the pressure-relief valve inlet diameter.
11. The size of discharge pipe from a pressure-relief valve must not be less than the outlet size of the pressure-relief valve. See ANSI/ASHRAE Standard 15 for requirements and guidelines on discharge piping.
12. Prior to installation or during pressure vessel testing, Sherwood pressure-relief valves should not be discharged. Any dirt in the system may imbed in the seat and prevent the pressure-relief valve from resealing properly.
13. The statements in this document reflect and are taken directly from ANSI/ASHRAE Standard 15-1994 and ANSI/ASHRAE Addendum 15c-2000. Please consult these standards for any additional information.

*Note: Relief valves are non-returnable. The policy helps maintain product integrity.*



SWD0215 ©2015 Sherwood Valve, LLC



[www.sherwoodvalve.com](http://www.sherwoodvalve.com) • 888.508.2583



Packed Angle Valves

Packed Angle Valves

Packed line valves are designed for a multitude of uses in refrigeration systems. When installed properly, these handy, forged brass packed angle valves provide easy accessibility and serviceability for the refrigeration system. All packed angle valves are provided with a brass seal cap.

The 617A Series charging and purging valves are designed to be installed on the branch or run of a solder-type tee. The valve can be readily positioned for easy access. These valves are

shipped loosely assembled for easy removal of parts prior to soldering. Reassemble after installation with a standard 3/8" square wrench.

Specialty packed angle valves are designed specifically for the refrigeration rack industry. The 600AX7-JB is designed for use with the transducer and offers connections to monitor and verify transducer readings and pressures. The 600B-6U6 Oil Leveler Valve offers a 3/8" SAE flare swivel for mounting on the oil leveler and a 3/8" SAE side outlet for oil

line connection. The 600B-4U4 SORIT or EPR Pilot Isolation Valve uses the same type of connections, in 1/4" SAE, as the 600B-6U6. The valve is designed for an inlet connection to the EPR or SORIT valve and an outlet connection to the pilot line of the suction header.

All Superior Packed Angle Valves incorporate a special packing that has been developed for use with all refrigerants.

Packed Angle Valves – 600A Series

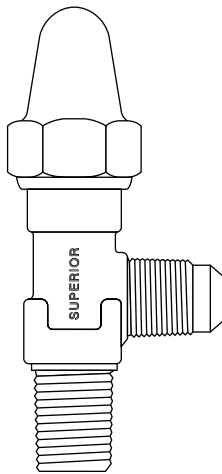

Part Number	IBCA Number	Size (Inches)			Socket for OD Tubing	Weight (lbs.)
		Bottom Inlet		Side Outlet		
		NPT	x	SAE		
600A-4B	57094	1/4		1/4	0.25	
600A-4C	57095	3/8		1/4	0.25	
600A-6B	57099	1/4		3/8	0.25	
600A-6C	57100	3/8		3/8	0.25	

Packed Angle Receiver Valves – 605 Series

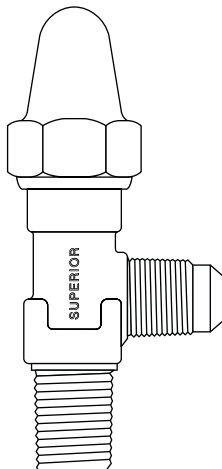

Part Number	IBCA Number	Size (Inches)			Socket for OD Tubing	Weight (lbs.)
		Bottom Inlet		Side Outlet		
		NPT	x	SAE		
605-6D	57112	1/2		3/8	0.50	
605-8B	57113	1/4		1/4	0.50	
605-8C	57114	3/8		1/2	0.50	
605-8D	57115	1/2		1/2	0.50	
606B-10D*	57119	1/2		3/8	0.50	
		NPT	x	FPT		
605-KB	57109	1/4		1/4	0.50	
		NPT	x	ODS		
605-10S	57110	1/2		3/8	0.50	

\* Backseating design.



## Packed Angle Valves

- Working pressure: 700 PSIG.
- Maximum temperature: 300° F.
- Minimum temperature: -40° F.
- Body construction: forged brass
- Seal cap construction: brass with copper gasket or nylon gasket.
- Steel stem with copper nickel plating
- UL® and cUL Listed
- Schrader core on 600AX7-JB must be removed prior to soldering.
- For use with CO<sub>2</sub>, CFC, HFC and HCFC refrigerants listed in CAN/CSA B52 and ANSI/ASHRAE 15 Section 9.2.
- For gases and liquids not listed, please consult factory.
- Spare Parts List on pp. 36–37.

### Packed Angle Valves – 600A Series

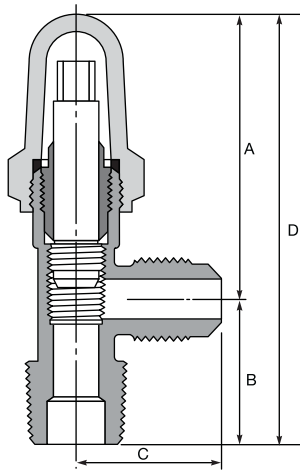

Part Number	Dimensions (Inches)			
	A	B	C	D
600A-4B	2 <sup>3</sup> / <sub>32</sub>	1 <sup>1</sup> / <sub>32</sub>	1 <sup>1</sup> / <sub>32</sub>	3 <sup>1</sup> / <sub>8</sub>
600A-4C	2 <sup>3</sup> / <sub>32</sub>	1 <sup>1</sup> / <sub>32</sub>	1 <sup>1</sup> / <sub>32</sub>	3 <sup>1</sup> / <sub>8</sub>
600A-6B	2 <sup>3</sup> / <sub>32</sub>	1 <sup>1</sup> / <sub>32</sub>	1 <sup>1</sup> / <sub>32</sub>	3 <sup>1</sup> / <sub>8</sub>
600A-6C	2 <sup>3</sup> / <sub>32</sub>	1 <sup>1</sup> / <sub>32</sub>	1 <sup>1</sup> / <sub>32</sub>	3 <sup>1</sup> / <sub>8</sub>

### Packed Angle Receiver Valves – 605 Series

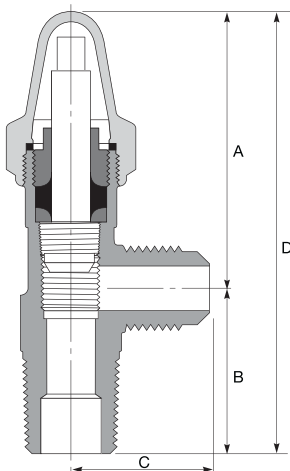

Part Number	Dimensions (Inches)			
	A	B	C	D
605-6D	2 <sup>1</sup> / <sub>2</sub>	1 <sup>15</sup> / <sub>32</sub>	1 <sup>1</sup> / <sub>16</sub>	3 <sup>21</sup> / <sub>32</sub>
605-8B	2 <sup>1</sup> / <sub>2</sub>	1 <sup>15</sup> / <sub>32</sub>	1 <sup>1</sup> / <sub>16</sub>	3 <sup>31</sup> / <sub>32</sub>
605-8C	2 <sup>1</sup> / <sub>2</sub>	1 <sup>15</sup> / <sub>32</sub>	1 <sup>1</sup> / <sub>16</sub>	3 <sup>31</sup> / <sub>32</sub>
605-8D	2 <sup>1</sup> / <sub>2</sub>	1 <sup>15</sup> / <sub>32</sub>	1 <sup>1</sup> / <sub>16</sub>	3 <sup>31</sup> / <sub>32</sub>
605-10S	2 <sup>1</sup> / <sub>2</sub>	1 <sup>15</sup> / <sub>32</sub>	1 <sup>1</sup> / <sub>16</sub>	3 <sup>31</sup> / <sub>32</sub>
605-KB	2 <sup>1</sup> / <sub>2</sub>	1 <sup>15</sup> / <sub>32</sub>	1 <sup>1</sup> / <sub>4</sub>	3 <sup>31</sup> / <sub>32</sub>
606B-10D*	2 <sup>5</sup> / <sub>8</sub>	1 <sup>3</sup> / <sub>4</sub>	1 <sup>1</sup> / <sub>16</sub>	4 <sup>3</sup> / <sub>8</sub>

\*Backseating design.

Packed Angle Valves

Packed Angle Charging and Purging Valves – 617A Series

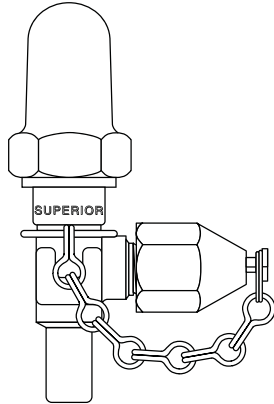

Part Number	IBCA Number	Size (Inches)			Weight (lbs.)
		Bottom Inlet		Side Outlet	
		ODS	x	SAE	
617A-4S4	57163	1/4		1/4	0.25
617A-6S4	57164	3/8		1/4	0.25
617A-6S6	57165	3/8		3/8	0.25
617A-8S4	57166	1/2		1/4	0.375
617A-8S6	57167	1/2		3/8	0.375
617A-10S4	57161	3/4		1/4	0.375
617A-10S6	57162	3/4		3/8	0.375

Transducer Valve

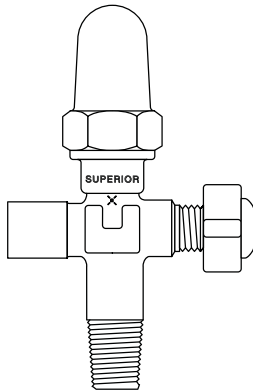

Part Number	IBCA Number	Size (Inches)				Weight (lbs.)
		Inlet		Outlet*		
		NPT/ODS	x	FPT	x SAE	
600AX7-JB	57107	1/4		1/8	1/4	0.25

\* 1/8" FPT female side connection for transducer fitting used to monitor pressure.

† 1/4" SAE flare side connection with Schrader core for manual pressure check with gauge to verify transducer readings.

Oil Leveler/SORIT or EPR Pilot Isolation Valve

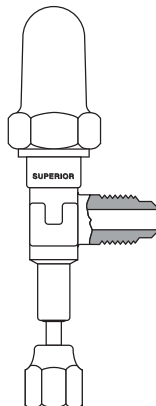

Part Number	IBCA Number	Size (Inches)			Weight (lbs.)
		Bottom Inlet		Side Outlet	
		fSAE	x	mSAE	
600B-4U4	59252	1/4		1/4	0.375
600B-6U6	59253	3/8		3/8	0.375

**Packed Angle Charging and Purging Valves — 617A Series**

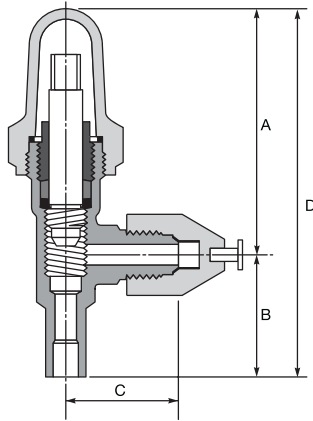

Catalog Number	Dimensions (Inches)			
	A	B	C	D
617A-4S4	2 <sup>3</sup> / <sub>32</sub>	1 <sup>1</sup> / <sub>32</sub>	3 <sup>1</sup> / <sub>32</sub>	3 <sup>1</sup> / <sub>8</sub>
617A-6S4	2 <sup>3</sup> / <sub>32</sub>	1 <sup>1</sup> / <sub>32</sub>	3 <sup>1</sup> / <sub>32</sub>	3 <sup>1</sup> / <sub>8</sub>
617A-6S6	2 <sup>3</sup> / <sub>32</sub>	1 <sup>1</sup> / <sub>32</sub>	1 <sup>1</sup> / <sub>32</sub>	3 <sup>1</sup> / <sub>8</sub>
617A-8S4	2 <sup>3</sup> / <sub>32</sub>	1 <sup>1</sup> / <sub>32</sub>	3 <sup>1</sup> / <sub>32</sub>	3 <sup>1</sup> / <sub>8</sub>
617A-8S6	2 <sup>3</sup> / <sub>32</sub>	1 <sup>1</sup> / <sub>32</sub>	1 <sup>1</sup> / <sub>32</sub>	3 <sup>1</sup> / <sub>8</sub>
617A-10S4	2 <sup>3</sup> / <sub>32</sub>	1 <sup>1</sup> / <sub>32</sub>	3 <sup>1</sup> / <sub>32</sub>	3 <sup>1</sup> / <sub>8</sub>
617A-10S6	2 <sup>3</sup> / <sub>32</sub>	1 <sup>1</sup> / <sub>32</sub>	1 <sup>1</sup> / <sub>32</sub>	3 <sup>1</sup> / <sub>8</sub>

**Transducer Valve**

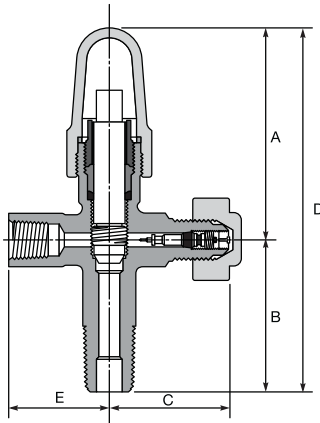

Part Number	Dimensions (Inches)				
	A	B	C	D	E
600AX7-JB	2 <sup>3</sup> / <sub>32</sub>	1 <sup>1</sup> / <sub>2</sub>	1 <sup>1</sup> / <sub>32</sub>	3 <sup>19</sup> / <sub>32</sub>	1

**Oil Leveler/SORIT or EPR Pilot Isolation Valve**

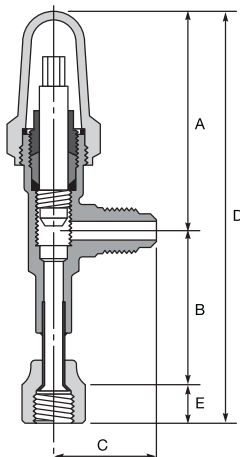

Part Number	Dimensions (Inches)				
	A	B	C	D	E
600B-4U4	2 <sup>3</sup> / <sub>32</sub>	1 <sup>31</sup> / <sub>32</sub>	1 <sup>1</sup> / <sub>32</sub>	4 <sup>15</sup> / <sub>32</sub>	1 <sup>13</sup> / <sub>32</sub>
600B-6U6	2 <sup>3</sup> / <sub>32</sub>	1 <sup>31</sup> / <sub>32</sub>	1 <sup>1</sup> / <sub>32</sub>	4 <sup>19</sup> / <sub>32</sub>	1 <sup>7</sup> / <sub>32</sub>

### CFA Uni-Form® Shells

- All-brass one-piece shell, significantly better than steel.
- 700 PSIG working pressure
- May be silver brazed for permanent installation and protection of system.
- Minimal space required for installation.
- No paint to peel.
- No rust or corrosion.
- Single cartridge design.
- Access valve (1/4" SAE) readily permits pressure drop readings.
- Corrosion-resistant stainless steel bolts permit easy access for changing of cartridges.
- No welds or solder joints, no chance of leaks!
- UL® and cUL Listed, File No. SA 2718 (N).

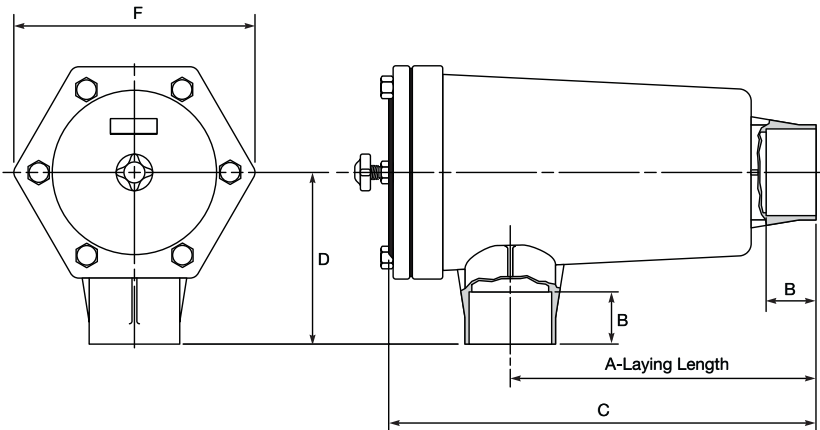

### Shells Only – Cartridges Not Included

Part Number	IBCA Number	Conn. ODS	Bolt Torque (ft. lbs.)	Nominal Shell Dia. E (in.)	A (in.)	B (in.)	F (in.)	C (in.)	D (in.)	Weight (lbs.)
2CFA-10S	56367	5/8	12	2	5 <sup>31</sup> / <sub>32</sub>	1/2	4	7 <sup>1</sup> / <sub>8</sub>	2	6 <sup>1</sup> / <sub>2</sub>
2CFA-12S	56368	3/4	12	2	5 <sup>31</sup> / <sub>32</sub>	5/8	4	7 <sup>1</sup> / <sub>8</sub>	2	6 <sup>1</sup> / <sub>2</sub>
2CFA-14S	56369	7/8	12	2	6 <sup>19</sup> / <sub>32</sub>	3/4	4	8 <sup>1</sup> / <sub>2</sub>	2 <sup>5</sup> / <sub>8</sub>	6 <sup>1</sup> / <sub>2</sub>
2CFA-18S	56370	1 <sup>1</sup> / <sub>8</sub>	12	2	6 <sup>19</sup> / <sub>32</sub>	1	4	8 <sup>1</sup> / <sub>2</sub>	2 <sup>5</sup> / <sub>8</sub>	6 <sup>1</sup> / <sub>2</sub>
3CFA-8S*	56476	1/2	14	3	6 <sup>3</sup> / <sub>4</sub>	3/8	4 <sup>5</sup> / <sub>8</sub>	9 <sup>9</sup> / <sub>16</sub>	2 <sup>15</sup> / <sub>16</sub>	9
3CFA-10S*	56470	5/8	14	3	6 <sup>3</sup> / <sub>4</sub>	1/2	4 <sup>5</sup> / <sub>8</sub>	9 <sup>9</sup> / <sub>16</sub>	2 <sup>15</sup> / <sub>16</sub>	9
3CFA-14S	56471	7/8	14	3	6 <sup>3</sup> / <sub>4</sub>	3/4	4 <sup>5</sup> / <sub>8</sub>	9 <sup>9</sup> / <sub>16</sub>	2 <sup>15</sup> / <sub>16</sub>	9
3CFA-18S	56472	1 <sup>1</sup> / <sub>8</sub>	14	3	7 <sup>1</sup> / <sub>16</sub>	1	4 <sup>5</sup> / <sub>8</sub>	9 <sup>9</sup> / <sub>16</sub>	3 <sup>1</sup> / <sub>4</sub>	9 <sup>1</sup> / <sub>4</sub>
3CFA-22S	56473	1 <sup>1</sup> / <sub>8</sub>	14	3	7 <sup>7</sup> / <sub>16</sub>	1 <sup>1</sup> / <sub>8</sub>	4 <sup>5</sup> / <sub>8</sub>	9 <sup>9</sup> / <sub>16</sub>	3 <sup>3</sup> / <sub>8</sub>	9 <sup>1</sup> / <sub>4</sub>
3CFA-26S	56474	1 <sup>1</sup> / <sub>8</sub>	14	3	7 <sup>7</sup> / <sub>16</sub>	1 <sup>3</sup> / <sub>16</sub>	4 <sup>5</sup> / <sub>8</sub>	10	3 <sup>3</sup> / <sub>16</sub>	9 <sup>1</sup> / <sub>2</sub>
3CFA-34S	56475	2 <sup>1</sup> / <sub>8</sub>	14	3	7 <sup>7</sup> / <sub>16</sub>	1 <sup>3</sup> / <sub>16</sub>	4 <sup>5</sup> / <sub>8</sub>	10 <sup>10</sup> / <sub>16</sub>	3 <sup>13</sup> / <sub>16</sub>	9 <sup>1</sup> / <sub>4</sub>
4CFA-14S*	56851	7/8	20	4	7 <sup>7</sup> / <sub>8</sub>	3/4	5 <sup>1</sup> / <sub>2</sub>	10 <sup>17</sup> / <sub>32</sub>	3 <sup>17</sup> / <sub>32</sub>	14 <sup>1</sup> / <sub>2</sub>
4CFA-18S*	56852	1 <sup>1</sup> / <sub>8</sub>	20	4	7 <sup>7</sup> / <sub>8</sub>	1	5 <sup>1</sup> / <sub>2</sub>	10 <sup>17</sup> / <sub>32</sub>	3 <sup>3</sup> / <sub>4</sub>	14 <sup>1</sup> / <sub>2</sub>
4CFA-22S	56853	1 <sup>1</sup> / <sub>8</sub>	20	4	7 <sup>7</sup> / <sub>16</sub>	1 <sup>1</sup> / <sub>8</sub>	5 <sup>1</sup> / <sub>2</sub>	10 <sup>7</sup> / <sub>8</sub>	3 <sup>3</sup> / <sub>8</sub>	14 <sup>1</sup> / <sub>2</sub>
4CFA-26S	56854	1 <sup>1</sup> / <sub>8</sub>	20	4	7 <sup>3</sup> / <sub>4</sub>	1 <sup>3</sup> / <sub>16</sub>	5 <sup>1</sup> / <sub>2</sub>	11 <sup>1</sup> / <sub>16</sub>	4 <sup>1</sup> / <sub>16</sub>	14 <sup>1</sup> / <sub>2</sub>
4CFA-34S	56855	2 <sup>1</sup> / <sub>8</sub>	20	4	8	1 <sup>3</sup> / <sub>16</sub>	5 <sup>1</sup> / <sub>2</sub>	11 <sup>3</sup> / <sub>8</sub>	4 <sup>5</sup> / <sub>16</sub>	14 <sup>3</sup> / <sub>4</sub>
4CFA-42S	56856	2 <sup>1</sup> / <sub>8</sub>	20	4	8 <sup>7</sup> / <sub>32</sub>	1 <sup>1</sup> / <sub>16</sub>	5 <sup>1</sup> / <sub>2</sub>	11 <sup>17</sup> / <sub>32</sub>	4 <sup>1</sup> / <sub>16</sub>	15 <sup>1</sup> / <sub>4</sub>
5CFA-34S	56894	2 <sup>1</sup> / <sub>8</sub>	35	5	8 <sup>3</sup> / <sub>4</sub>	1 <sup>3</sup> / <sub>16</sub>	7 <sup>1</sup> / <sub>4</sub>	12 <sup>1</sup> / <sub>2</sub>	4 <sup>3</sup> / <sub>4</sub>	24
5CFA-42S	56895	2 <sup>1</sup> / <sub>8</sub>	35	5	8 <sup>3</sup> / <sub>4</sub>	1 <sup>3</sup> / <sub>16</sub>	7 <sup>1</sup> / <sub>4</sub>	12 <sup>1</sup> / <sub>16</sub>	4 <sup>3</sup> / <sub>8</sub>	24
5CFA-50S	56896	3 <sup>1</sup> / <sub>8</sub>	35	5	8 <sup>3</sup> / <sub>16</sub>	1 <sup>13</sup> / <sub>16</sub>	7 <sup>1</sup> / <sub>4</sub>	12 <sup>3</sup> / <sub>8</sub>	4 <sup>3</sup> / <sub>16</sub>	24

\* Liquid line service only.

### Replacement Flange Gaskets for CFA Shells

Part Number	IBCA Number	For Shell Number
AG2	51003	2CFA
AG3	51004	3CFA
AG4	51005	4CFA
AG5	51006	5CFA

## Suction Line Filters

### CFA Uni-Form® Shell Replaceable Cartridges



Type F Filter Cartridge

#### F Series Replaceable Filter Cartridge

- Super-pleated filter media provides up to twice the filter area of any other pleated or non-pleated filter cartridge today.
- Traps solid contaminants down to 10 microns in size.
- Integral end rings are permanently bonded to filter media.
- Stainless steel helical wire spring within the filter eliminates the possibility of cartridge collapse under normal operation conditions.



Type DF Filter-Drier Cartridge

#### DF Series Replaceable Dual-Purpose Filter Plus Drier Cartridge

- Molded solid core of specially blended molecular sieve and activated alumina produces a dual-purpose suction line filter/drier of unusually high efficiency and capacity.
- Can be used for system clean-ups or on a permanent use basis.
- Solid contaminants never reach the desiccant core.
- Moisture and acids are efficiently removed from the refrigerant stream.
- All filters or filters plus driers should be changed when pressure drop across cartridge increases significantly.
- All filters or filters plus driers are rated in accordance with ARI standard 730-86.
- Always follow compressor manufacturer's recommendations.

#### Replaceable Cartridges – Type F Filter

Part Number	IBCA Number	For Shell Number	Cartridge OD (in.)	Cartridge Length (in.)	Filter Area (in. <sup>2</sup> )	Standard Package	Weight per Package (lbs.)
F25A	51071	2CFA	1 <sup>23</sup> / <sub>32</sub>	6 <sup>9</sup> / <sub>16</sub>	66	12	4 <sup>1</sup> / <sub>4</sub>
F35A	51072	3CFA	2 <sup>9</sup> / <sub>16</sub>	6 <sup>23</sup> / <sub>32</sub>	115	12	6
F45A	51073	4CFA	3 <sup>1</sup> / <sub>32</sub>	7 <sup>1</sup> / <sub>16</sub>	189	12	9 <sup>3</sup> / <sub>4</sub>
F55A	51074	5CFA	4 <sup>1</sup> / <sub>16</sub>	8 <sup>7</sup> / <sub>32</sub>	270	12	11 <sup>3</sup> / <sub>4</sub>

#### Replaceable Cartridges – Type DF for Clean-up and Permanent Use

Part Number	IBCA Number	For Shell Number	Cartridge OD (in.)	Cartridge Length (in.)	Filter Area (in. <sup>2</sup> )	Standard Package	Weight per Package (lbs.)
DF25A	51053	2CFA	1 <sup>23</sup> / <sub>32</sub>	6 <sup>1</sup> / <sub>32</sub>	66	12	5 <sup>3</sup> / <sub>4</sub>
DF35A	51059	3CFA	2 <sup>9</sup> / <sub>16</sub>	6 <sup>23</sup> / <sub>32</sub>	115	12	10 <sup>1</sup> / <sub>2</sub>
DF45A	51060	4CFA	3 <sup>1</sup> / <sub>32</sub>	7 <sup>1</sup> / <sub>32</sub>	189	12	17 <sup>1</sup> / <sub>4</sub>
DF55A	51061	5CFA	4 <sup>1</sup> / <sub>16</sub>	8 <sup>7</sup> / <sub>32</sub>	270	12	24 <sup>1</sup> / <sub>2</sub>

Suction Line Filters

CFA Uni-Form® Shell Replaceable Cartridges

Selection and Ratings of Shells and Cartridges for R12, R22, R502

Part Number	Conn. ODS (Inches)	Permanent Filter Cartridge and Surface Area	Temporary Clean-Up Cartridge and Surface Area	Maximum Tonnage Ratings													
				Evaporation Temperatures													
				-40° F			-20° F			0° F			20° F			40° F	
				Pressure Drop (psi)													
				0.5	0.5	0.5	1.0	1.0	1.0	1.5	1.5	1.5	2.0	2.0	2.0	3.0	3.0
				Refrigerant Number													
	R22	R502	R12	R22	R502	R12	R22	R502	R12	R22	R502	R12	R22	R502			
2CFA-10S	0.625	F25A 66 sq. in.	DF25A 66 sq. in.	0.7	0.6	0.6	1.4	1.1	1.2	2.2	1.8	1.9	3.3	2.6	2.7	5.1	4.1
2CFA-12S	0.750			1.1	0.9	1.0	2.1	1.6	1.8	3.3	2.6	2.8	4.9	3.9	4.1	7.5	6.1
2CFA-14S	0.875			1.3	1.0	1.1	2.5	1.9	2.1	3.9	3.1	3.3	5.7	4.6	4.8	8.8	7.2
2CFA-18S	1.125			2.0	1.5	1.7	3.7	2.9	3.2	5.9	4.7	5.0	8.8	7.0	7.3	13.5	11.0
3CFA-14S	0.875	F35A 115 sq. in.	DF35A 115 sq. in.	1.4	1.1	1.2	2.6	2.1	2.2	4.2	3.3	3.5	6.1	4.9	5.1	9.4	7.7
3CFA-18S	1.125			2.2	1.7	1.9	4.1	3.2	3.5	6.6	5.2	5.5	9.7	7.8	8.1	15.0	12.0
3CFA-22S	1.375			3.5	2.7	3.0	6.6	5.2	5.6	10.5	8.3	8.8	15.5	12.4	13.0	24.0	19.3
3CFA-26S	1.625			4.3	3.3	3.7	8.1	6.3	6.9	12.8	10.2	10.8	19.0	15.2	15.8	29.0	24.0
3CFA-34S	2.125			5.7	4.4	4.9	10.7	8.4	9.1	17.0	13.5	14.3	25.0	20.0	21.0	38.0	31.0
4CFA-22S	1.375	F45A 189 sq. in.	DF45A 189 sq. in.	3.7	2.9	3.2	7.0	5.5	5.9	11.0	8.8	9.3	16.3	13.0	13.6	25.0	20.0
4CFA-26S	1.625			4.6	3.6	4.0	8.7	6.8	7.4	14.0	11.0	11.7	20.0	16.4	17.0	31.0	26.0
4CFA-34S	2.125			7.8	6.0	6.7	14.6	11.5	12.4	23.0	18.5	19.6	34.0	28.0	29.0	53.0	43.0
4CFA-42S	2.625			9.5	7.3	8.1	17.8	14.0	15.1	29.0	23.0	24.0	42.0	34.0	35.0	64.0	52.0
5CFA-34S	2.125	F55A 270 sq. in.	DF55A 270 sq. in.	9.4	7.2	8.1	17.6	13.8	15.0	28.0	22.0	24.0	41.0	33.0	34.0	63.0	52.0
5CFA-42S	2.625			12.4	9.6	10.7	23.0	18.2	20.0	37.0	29.0	31.0	54.0	44.0	45.0	84.0	68.0
5CFA-50S	3.125			15.3	11.8	13.2	29.0	23.0	24.0	46.0	36.0	38.0	67.0	54.0	56.0	103.0	84.0

Part Number	Conn. ODS (Inches)	Permanent Filter Plus Drier Cartridge and Surface Area	Maximum Tonnage Ratings													
			Evaporation Temperatures													
			-40° F			-20° F			0° F			20° F			40° F	
			Pressure Drop (psi)													
			0.5	0.5	0.5	1.0	1.0	1.0	1.5	1.5	1.5	2.0	2.0	2.0	3.0	3.0
			Refrigerant Number													
	R22	R502	R12	R22	R502	R12	R22	R502	R12	R22	R502	R12	R22	R502		
2CFA-10S	0.625	DF25A 66 sq. in.	0.7	0.5	0.6	1.3	1.0	1.1	2.0	1.6	1.7	3.0	2.4	2.5	4.6	3.8
2CFA-12S	0.750		1.0	0.7	0.8	1.8	1.4	1.5	2.9	2.3	2.4	4.2	3.4	3.5	6.5	5.3
2CFA-14S	0.875		1.1	0.9	1.0	2.1	1.6	1.8	3.3	2.6	2.8	4.9	3.9	4.1	7.5	6.1
2CFA-18S	1.125		1.4	1.1	1.2	2.7	2.1	2.3	4.3	3.4	3.6	6.3	5.1	5.3	9.7	7.9
3CFA-14S	0.875	DF35A 115 sq. in.	1.3	1.0	1.1	2.5	1.9	2.1	3.9	3.1	3.3	5.8	4.6	4.8	8.9	7.2
3CFA-18S	1.125		2.0	1.6	1.7	3.8	3.0	3.2	6.0	4.8	5.1	8.9	7.1	7.4	13.6	11.1
3CFA-22S	1.375		2.9	2.2	2.5	5.4	4.2	4.6	8.6	6.8	7.3	12.7	10.2	10.6	19.5	15.9
3CFA-26S	1.625		3.4	2.6	2.9	6.3	5.0	5.4	10.0	8.0	8.4	14.8	12.0	12.3	23.0	18.5
3CFA-34S	2.125		4.2	3.2	3.6	7.8	6.1	6.7	12.5	9.9	10.5	18.3	14.7	15.3	28.0	23.0
4CFA-22S	1.375	DF45A 189 sq. in.	3.3	2.5	2.8	6.1	4.8	5.2	9.8	7.8	8.2	14.4	11.5	12.0	22.0	18.0
4CFA-26S	1.625		4.3	3.3	3.7	8.1	6.3	6.9	12.8	10.2	10.8	19.0	15.2	15.7	29.0	24.0
4CFA-34S	2.125		6.3	4.9	5.4	11.8	9.3	10.0	18.8	14.9	15.8	28.0	22.0	23.0	43.0	35.0
4CFA-42S	2.625		6.5	5.0	5.6	12.2	9.5	10.3	19.3	15.4	16.3	29.0	23.0	24.0	44.0	36.0
5CFA-34S	2.125	DF55A 270 sq. in.	7.5	5.8	6.4	14.0	11.0	12.0	22.0	17.8	18.8	33.0	27.0	28.0	51.0	41.0
5CFA-42S	2.625		9.0	7.0	7.8	17.0	13.3	14.4	27.0	22.0	23.0	40.0	32.0	33.0	61.0	50.0
5CFA-50S	3.125		10.7	8.3	9.2	20.0	15.8	17.1	32.0	25.0	27.0	47.0	38.0	39.0	72.0	59.0



# CFA Uni-Form® Shell Replaceable Cartridges

## Selection and Ratings of Shells and Cartridges for R404A, R134A

Part Number	Conn. ODS (Inches)	Permanent Filter Cartridge and Surface Area	Temporary Clean-Up Cartridge and Surface Area	Maximum Tonnage Ratings								
				Evaporation Temperatures								
				-40° F	-20° F		0° F		20° F		40° F	
				Pressure Drop (psi)								
				0.5	0.5	1.0	1.0	1.5	1.5	2.0	2.0	3.0
				Refrigerant Number								
				R404A	R134A	R404A	R134A	R404A	R134A	R404A		
2CFA-10S	0.625	F25A 66 sq. in.	DF25A 66 sq. in.	0.6	0.7	1.1	1.3	1.8	2.1	2.8	3.2	4.4
2CFA-12S	0.750			0.8	1.0	1.6	1.9	2.7	3.2	4.1	4.7	6.4
2CFA-14S	0.875			1.0	1.2	1.9	2.3	3.2	3.7	4.6	5.6	7.6
2CFA-18S	1.125			1.5	1.8	3.0	3.5	4.9	5.7	7.3	8.5	11.6
3CFA-14S	0.875	F35A 115 sq. in.	DF35A 115 sq. in.	1.1	1.3	2.1	2.5	3.4	4.0	5.1	6.0	8.1
3CFA-18S	1.125			1.7	2.0	3.3	3.9	5.4	6.3	8.1	9.4	12.8
3CFA-22S	1.375			2.7	3.2	5.2	6.2	8.7	10.0	12.9	15.1	20.5
3CFA-26S	1.625			3.3	3.9	6.4	7.6	10.6	12.3	15.8	18.4	25.0
3CFA-34S	2.125			4.4	5.2	8.5	10.0	14.0	16.2	20.9	24.4	33.1
4CFA-22S	1.375			2.8	3.4	5.5	6.5	9.1	10.6	13.6	15.9	21.6
4CFA-26S	1.625	F45A 189 sq. in.	DF45A 189 sq. in.	3.6	4.3	6.9	8.2	11.4	13.2	17.1	19.9	27.0
4CFA-34S	2.125			6.0	7.1	11.6	13.7	19.2	22.2	28.6	33.3	45.3
4CFA-42S	2.625			7.3	8.7	14.2	16.7	23.4	27.1	34.9	40.7	55.3
5CFA-34S	2.125			7.2	8.6	14.0	16.5	23.1	26.7	34.5	40.1	54.6
5CFA-42S	2.625	F55A 270 sq. in.	DF55A 270 sq. in.	9.5	11.4	18.5	21.8	30.5	35.3	45.6	53.0	72.1
5CFA-50S	3.125			11.8	14.2	23.0	27.2	38.0	44.0	56.8	66.1	89.9

Part Number	Conn. ODS (Inches)	Permanent Filter Plus Drier Cartridge and Surface Area	Maximum Tonnage Ratings								
			Evaporation Temperatures								
			-40° F	-20° F		0° F		20° F		40° F	
			Pressure Drop (psi)								
			0.5	0.5	1.0	1.0	1.5	1.5	2.0	2.0	3.0
			Refrigerant Number								
				R404A	R134A	R404A	R134A	R404A	R134A	R404A	
2CFA-10S	0.625	DF25A 66 sq. in.	0.5	0.6	1.0	1.2	1.7	1.9	2.5	2.9	4.0
2CFA-12S	0.750		0.7	0.9	1.4	1.7	2.4	2.7	3.5	4.1	5.6
2CFA-14S	0.875		0.9	1.0	1.7	2.0	2.7	3.2	4.1	4.8	6.5
2CFA-18S	1.125		1.1	1.3	2.1	2.5	3.5	4.1	5.3	6.2	8.4
3CFA-14S	0.875	DF35A 115 sq. in.	1.0	1.2	2.0	2.3	3.2	3.7	4.8	5.6	7.6
3CFA-18S	1.125		1.5	1.9	3.0	3.6	5.0	5.8	7.4	8.6	11.0
3CFA-22S	1.375		2.2	2.6	4.3	5.1	7.1	8.2	10.6	12.4	16.8
3CFA-26S	1.625		2.6	3.1	5.0	5.9	8.3	9.6	12.4	14.4	19.6
3CFA-34S	2.125		3.2	3.8	6.2	7.3	10.3	11.9	15.3	17.8	24.3
4CFA-22S	1.375		2.5	3.0	4.9	5.9	8.0	9.3	12.0	14.0	19.0
4CFA-26S	1.625	DF45A 189 sq. in.	3.3	3.9	6.4	7.6	10.6	12.2	15.8	18.4	25.0
4CFA-34S	2.125		4.8	5.8	9.4	11.1	15.5	17.9	23.1	26.9	36.6
4CFA-42S	2.625		5.0	5.9	9.6	11.4	15.9	18.4	23.8	27.7	37.7
5CFA-34S	2.125		5.7	6.9	11.2	13.2	18.4	21.4	27.6	32.1	43.6
5CFA-42S	2.625	DF55A 270 sq. in.	6.9	8.3	13.5	15.9	22.3	25.8	33.3	38.7	52.7
5CFA-50S	3.125		8.2	9.8	16.0	18.8	26.4	30.5	39.4	45.9	62.4



Suction Line Filters

CFA Uni-Form® Shell Replaceable Cartridges

Selection and Ratings of Shells and Cartridges for R507

Part Number	Conn. ODS (Inches)	Permanent Filter Cartridge and Surface Area	Temporary Clean-Up Cartridge and Surface Area	Maximum Tonnage Ratings					
				Evaporation Temperatures					
				-40° F	-20° F	0° F	20° F	40° F	
				Pressure Drop (psi)					
				0.5	1.0	1.5	2.0	3.0	
				Refrigerant Number					
					R507	R507	R507	R507	R507
2CFA-10S	0.625	F25A 66 sq. in.	DF25A 66 sq. in.	0.6	1.2	1.9	2.9	4.5	
2CFA-12S	0.750			0.9	1.7	2.8	4.2	6.6	
2CFA-14S	0.875			1.0	2.0	3.3	5.0	7.8	
2CFA-18S	1.125			1.6	3.1	5.0	7.6	11.9	
3CFA-14S	0.875	F35A 115 sq. in.	DF35A 115 sq. in.	1.1	2.2	3.5	5.3	8.3	
3CFA-18S	1.125			1.8	3.4	5.6	8.4	13.2	
3CFA-22S	1.375			2.8	5.4	8.9	13.4	21.1	
3CFA-26S	1.625			3.4	6.7	10.9	16.4	25.7	
3CFA-34S	2.125			4.6	8.8	14.4	21.7	34.1	
4CFA-22S	1.375	F45A 189 sq. in.	DF45A 189 sq. in.	3.0	5.7	9.4	14.1	22.2	
4CFA-26S	1.625			3.7	7.2	11.7	17.7	27.8	
4CFA-34S	2.125			6.2	12.0	19.7	29.7	46.6	
4CFA-42S	2.625			7.6	14.7	24.0	36.2	56.9	
5CFA-34S	2.125	F55A 270 sq. in.	DF55A 270 sq. in.	7.5	14.5	23.7	35.8	56.2	
5CFA-42S	2.625			9.9	19.2	31.3	47.2	74.2	
5CFA-50S	3.125			12.4	23.9	39.1	58.9	92.4	

Part Number	Conn. ODS (Inches)	Permanent Filter plus Drier Cartridge and Surface Area	Maximum Tonnage Ratings						
			Evaporation Temperatures						
			-40° F	-20° F	0° F	20° F	40° F		
			Pressure Drop (psi)						
			0.5	1.0	1.5	2.0	3.0		
			Refrigerant Number						
					R507	R507	R507	R507	R507
2CFA-10S	0.625	DF25A 66 sq. in.	0.5	1.1	1.7	2.6	4.1		
2CFA-12S	0.750		0.8	1.5	2.4	3.7	5.8		
2CFA-14S	0.875		0.9	1.7	2.8	4.3	6.7		
2CFA-18S	1.125		1.2	2.2	3.6	5.5	8.6		
3CFA-14S	0.875	DF35A 115 sq. in.	1.0	2.0	3.3	5.0	7.8		
3CFA-18S	1.125		1.6	3.1	5.1	7.7	12.1		
3CFA-22S	1.375		2.3	4.5	7.3	11.0	17.3		
3CFA-26S	1.625		2.7	5.2	8.5	12.8	20.1		
3CFA-34S	2.125		3.3	6.5	10.5	15.9	25.0		
4CFA-22S	1.375	DF45A 189 sq. in.	2.6	5.1	8.3	12.5	19.6		
4CFA-26S	1.625		3.4	6.6	10.9	16.4	25.7		
4CFA-34S	2.125		5.0	9.7	15.9	24.0	37.6		
4CFA-42S	2.625		5.2	10.0	16.4	24.7	38.7		
5CFA-34S	2.125	DF55A 270 sq. in.	6.0	11.6	19.0	28.6	44.9		
5CFA-42S	2.625		7.2	14.0	22.9	34.5	54.2		
5CFA-50S	3.125		8.6	16.6	27.1	40.9	64.1		

## Suction Line Cores for CFA Shells

### A25, A35, A45 and A55 Temporary Acid Removal Suction Line Cores for Temporary Installation in Place of “F” or “DF” Cartridges



The Acid Fighter is a temporary suction line core specifically designed to give you maximum acid removal performance in situations where extremely high acid conditions exist. When used in conjunction with a Superior DF filter drier cartridge, it gives you a “knockout” combination.

*Note: The DF cartridge is still satisfactory for routine acid removal and system clean-up.*

#### Features and Benefits of Acid Fighter Core

- Fewer system pump downs required to remove persistent acid condition.
- Fewer cores needed for system clean-up.
- The ability to remove other foreign materials: sludges, solids, oil residues, moisture and other contaminants normally found in air conditioning and refrigeration systems.
- More acid removal capability than other comparable suction line cores. This results from using a very special blend of field-proven desiccants.
- “Hot packaging” insures fully activated cores for field installation. Each core is individually packaged, as it comes from a vacuum oven, in a special heat-sealed foil bag to maintain the lowest residual moisture obtainable.
- System pressure drop is minimized because of large, open-mesh single-core bonded construction and large surface area.
- Maximum core permeability is due to uniformity of desiccant size and shape.
- Added compressor protection, because of a built-in double-mesh stainless steel screen on the outlet side of the core.
- Integral felt gaskets at each end of the core cushion against shock and eliminate need for extra gaskets in the package.
- High mechanical crush strength of the core precludes powdering.

#### Ratings for Temporary Acid Removal – R12, R22, and R502\*

*(\*Temporary refers to use during clean-up procedure while ΔP is being monitored.)*

Part Number	Conn. ODS (Inches)	Temporary High Capacity Acid Removal Core, Surface Area and Desiccant Volume	Maximum Tonnage Ratings													
			Evaporation Temperatures													
			-40° F		-20° F		0° F		20° F		40° F					
			Pressure Drop (psi)													
			1.0	1.0	1.0	2.0	2.0	2.0	3.0	3.0	3.0	4.0	4.0	6.0	8.0	8.0
Refrigerant Number																
			R22	R502	R12	R22	R502	R12	R22	R502	R12	R22	R502	R12	R22	R502
2CFA-10S	0.625	A25 35 sq. in. 13 cu. in.	0.89	0.69	0.78	1.68	1.32	1.44	2.67	2.13	2.28	3.92	3.17	4.09	6.95	5.70
2CFA-12S	0.750		1.26	0.98	1.09	2.37	1.86	2.04	3.77	3.00	3.22	5.53	4.47	5.77	9.80	8.03
2CFA-14S	0.875		1.55	1.20	1.34	2.91	2.29	2.50	4.62	3.68	3.95	6.79	5.49	7.09	12.04	9.86
2CFA-18S	1.125		2.01	1.56	1.74	3.78	2.97	3.25	6.01	4.79	5.13	8.82	7.13	9.21	15.64	12.81
3CFA-8S	0.500	A35 62 sq. in. 35 cu. in.	0.61	0.47	0.53	1.14	0.90	0.98	1.81	1.44	1.55	2.66	2.15	2.78	4.72	3.86
3CFA-10S	0.625		0.89	0.69	0.78	1.68	1.32	1.44	2.67	2.13	2.28	3.92	3.17	4.09	6.95	5.70
3CFA-14S	0.875		1.52	1.17	1.31	2.85	2.24	2.45	4.53	3.61	3.87	6.65	5.38	6.94	11.79	9.66
3CFA-18S	1.125		2.24	1.73	1.94	4.20	3.30	3.61	6.67	5.32	5.70	9.80	7.92	10.23	17.37	14.24
3CFA-22S	1.375		2.97	2.30	2.57	5.58	4.38	4.79	8.87	7.06	7.57	13.03	10.53	13.60	23.08	18.92
3CFA-26S	1.625		3.64	2.82	3.16	6.84	5.37	5.88	10.87	8.66	9.28	15.97	12.90	16.67	28.29	23.19
3CFA-34S	2.125	4.92	3.81	4.26	9.24	7.26	7.94	14.68	11.70	12.54	21.57	17.43	22.51	38.22	31.32	
4CFA-14S	0.875	A45 93 sq. in. 63 cu. in.	1.76	1.36	1.52	3.30	2.60	2.83	5.24	4.18	4.48	7.70	6.22	8.04	13.65	11.19
4CFA-18S	1.125		2.80	2.16	2.42	5.25	4.12	4.51	8.34	6.65	7.13	12.26	9.90	12.80	21.72	17.80
4CFA-22S	1.375		4.23	3.28	3.67	7.95	6.24	6.83	12.63	10.06	10.79	18.56	15.00	19.37	32.89	26.95
4CFA-26S	1.625		5.11	3.96	4.43	9.60	7.54	8.25	15.25	12.15	13.03	22.41	18.11	23.39	39.71	32.54
4CFA-34S	2.125		7.03	5.44	6.09	13.20	10.37	11.34	20.97	16.71	17.92	30.81	24.90	32.16	54.60	44.75
4CFA-42S	2.625	7.43	5.75	6.44	13.95	10.96	11.98	22.17	17.66	18.93	32.56	26.31	33.99	57.71	47.29	
5CFA-34S	2.125	A55 123 sq. in. 90 cu. in.	9.19	7.11	7.96	17.26	13.55	14.82	27.41	21.84	23.41	40.27	32.54	42.03	71.36	58.48
5CFA-42S	2.625		11.03	8.53	9.55	20.71	16.26	17.78	32.89	26.21	28.10	48.32	39.05	50.44	85.63	70.17
5CFA-50S	3.125		12.58	9.73	10.89	23.62	18.54	20.28	37.52	29.89	32.05	55.11	44.54	57.53	97.67	80.04

\* When actual pressure drop exceeds above recommended ΔP, replace “A” core with “DF” core within 15 minutes.

Suction Line Filters

CFA Uni-Form® Shell Temporary Cores

Ratings for Temporary Acid Removal – R404A, R134A

Part Number	Conn. ODS (Inches)	Temporary High Capacity Acid Removal Core, Surface Area and Desiccant Volume	Maximum Tonnage Ratings										
			Evaporation Temperatures										
			-40° F			-20° F			0° F		20° F		40° F
			Pressure Drop (psi)										
			1.0	1.0	2.0		2.0		3.0	3.0	4.0	6.0	8.0
			Refrigerant Number										
R404A	R134A	R404A	R134A	R404A	R134A	R404A	R134A	R404A	R134A	R404A			
2CFA-10S	0.625	A25 35 sq. in. 13 cu. in.	0.69	0.83	1.34	1.58	2.21	2.56	3.31	4.72	6.05		
2CFA-12S	0.750		0.97	1.16	1.89	2.23	3.12	3.62	4.67	6.65	8.53		
2CFA-14S	0.875		1.19	1.43	2.32	2.74	3.83	4.44	5.73	8.17	10.47		
2CFA-18S	1.125		1.55	1.86	3.02	3.56	4.98	5.77	7.45	10.61	13.60		
3CFA-8S	0.500	A35 62 sq. in. 35 cu. in.	0.47	0.56	0.91	1.07	1.50	1.74	2.25	3.20	4.10		
3CFA-10S	0.625		0.69	0.83	1.34	1.58	2.21	2.56	3.31	4.72	6.05		
3CFA-14S	0.875		1.17	1.40	2.27	2.68	3.75	4.35	5.61	8.00	10.26		
3CFA-18S	1.125		1.72	2.06	3.35	3.96	5.53	6.41	8.27	11.79	15.11		
3CFA-22S	1.375		2.29	2.74	4.45	5.26	7.35	8.52	10.99	15.66	20.08		
3CFA-26S	1.625		2.81	3.36	5.46	6.44	9.01	10.44	13.47	19.20	24.61		
3CFA-34S	2.125		3.79	4.54	7.37	8.70	12.17	14.10	16.20	25.94	33.25		
4CFA-14S	0.875		1.35	1.62	2.63	3.11	4.35	5.04	6.50	9.26	11.87		
4CFA-18S	1.125	2.15	2.58	4.19	4.95	6.92	8.01	10.34	14.74	18.89			
4CFA-22S	1.375	3.26	3.91	6.34	7.49	10.47	12.13	15.66	22.32	28.61			
4CFA-26S	1.625	3.94	4.72	7.66	9.04	12.64	14.65	18.91	26.95	34.55			
4CFA-34S	2.125	5.42	6.49	10.53	12.44	17.39	20.15	26.00	37.05	47.50			
4CFA-42S	2.625	5.73	6.85	11.13	13.14	18.37	21.29	27.48	39.16	50.20			
5CFA-34S	2.125	A55 123 sq. in. 90 cu. in.	7.08	8.47	13.76	16.25	22.72	26.33	33.98	48.42	62.07		
5CFA-42S	2.625		8.50	10.17	16.51	19.50	27.26	31.59	40.77	58.10	74.49		
5CFA-50S	3.125		9.69	11.60	18.83	22.24	31.10	36.03	46.50	66.27	84.96		

\* When actual pressure drop exceeds above recommended ΔP, replace "A" core with "DF" core within 15 minutes.

Ratings for Temporary Acid Removal – R507

Part Number	Conn. ODS (Inches)	Temporary High Capacity Acid Removal Core, Surface Area and Desiccant Volume	Maximum Tonnage Ratings										
			Evaporation Temperatures										
			-40° F			-20° F			0° F		20° F		40° F
			Pressure Drop (psi)										
			1.0	1.0	2.0		2.0		3.0	3.0	4.0	6.0	8.0
			Refrigerant Number										
R507	R507	R507	R507	R507	R507	R507	R507	R507	R507	R507			
2CFA-10S	0.625	A25 35 sq. in. 13 cu. in.	0.72	1.39			2.28		3.43		6.22		
2CFA-12S	0.750		1.01	1.96			3.21		4.84		8.77		
2CFA-14S	0.875		1.25	2.41			3.94		5.94		10.77		
2CFA-18S	1.125		1.62	3.13			5.12		7.72		13.99		
3CFA-8S	0.500	A35 62 sq. in. 35 cu. in.	0.49	0.94			1.54		2.33		4.22		
3CFA-10S	0.625		0.72	1.39			2.28		3.43		6.22		
3CFA-14S	0.875		1.22	2.36			3.86		5.82		10.55		
3CFA-18S	1.125		1.80	3.48			5.69		8.58		15.55		
3CFA-22S	1.375		2.39	4.62			7.56		11.40		20.65		
3CFA-26S	1.625		2.93	5.67			9.27		13.97		25.32		
3CFA-34S	2.125		3.96	7.66			12.52		18.87		34.20		
4CFA-14S	0.875		1.41	2.73			4.47		6.74		12.21		
4CFA-18S	1.125	2.25	4.35			7.11		10.72		19.43			
4CFA-22S	1.375	3.40	6.59			10.77		16.24		29.43			
4CFA-26S	1.625	4.11	7.95			13.00		19.61		35.53			
4CFA-34S	2.125	5.65	10.94			17.88		26.96		48.86			
4CFA-42S	2.625	5.97	11.56			18.90		28.49		51.63			
5CFA-34S	2.125	A55 123 sq. in. 90 cu. in.	7.39	14.29			23.37		35.23		63.85		
5CFA-42S	2.625		8.87	17.15			28.04		42.27		76.62		
5CFA-50S	3.125		10.11	19.56			31.98		48.22		87.39		

\* When actual pressure drop exceeds above recommended ΔP, replace "A" core with "DF" core within 15 minutes.



## CD35, CD45 and CD55 Char-Core® Liquid Line Cores



### Features and Benefits of Char-Core® Liquid Line Cores

- Wax build-up is prevented due to a high percentage of activated charcoal desiccant providing optimum wax adsorption.
- This special formulated blend gives Char-Core® liquid line cores the ability to remove not only wax, but virtually all other contaminants found in air conditioning and refrigeration systems.
- Maximum core permeability due to uniformity of desiccant size and shape.
- System pressure drop is minimized (along with the possibility of flash gas) because of the large, open-mesh, single-core bonded construction and large surface area.
- “Hot packaging” prepares cores for field installation. Each core comes from a vacuum oven and is individually packaged in a special heat-sealed foil bag to maintain total dryness.
- High mechanical crush strength of the new Char-Core® exceeds industry minimum standards and precludes powdering.
- Added compressor protection with a built-in double-mesh stainless screen on the outlet side of the core.
- Integral felt gaskets at each end of the Char-Core® cushion against shock and eliminate the need for extra gaskets in the package.
- High capacity, replaceable for the removal of wax, moisture and acids from refrigeration and air conditioning systems.

### Ratings for CD35 Liquid Line Char-Core® 65 sq. in. Filter Surface / 35 cu. in. Desiccant

Part Number	ODS (Inches)	R12		R22		R502		Tonnage Recommendations								
		Tons Flow 1#ΔP	Water Capacity		Tons Flow 1#ΔP	Water Capacity		Tons Flow 1#ΔP	Water Capacity		Comm. and Low Temperature			Air Conditioning		
			75° F	125° F		75° F	125° F		75° F	125° F	R12	R22	R502	R12	R22	R502
3CFA-8S	½	8.0	969	841	10.5	884	862	7.1	841	705	5	7½	5	7½	8	6
3CFA-10S	¾	12.2			16.0			10.7			7½	10	7½	10	12	10
3CFA-14S	1	13.0			17.0			11.4			10	12	10	12	15	11
3CFA-18S	1½	20.4			26.8			18.0			15	18	12	18	20	15
3CFA-22S	1¾	23.9			31.4			21.1			18	20	15	20	25	20

### Ratings for CD45 Liquid Line Char-Core® 93 sq. in. Filter Surface / 63 cu. in. Desiccant

Part Number	ODS (Inches)	R12		R22		R502		Tonnage Recommendations								
		Tons Flow 1#ΔP	Water Capacity		Tons Flow 1#ΔP	Water Capacity		Tons Flow 1#ΔP	Water Capacity		Comm. and Low Temperature			Air Conditioning		
			75° F	125° F		75° F	125° F		75° F	125° F	R12	R22	R502	R12	R22	R502
4CFA-14S	¾	20.4	1724	1496	26.9	1572	1534	18.0	1496	1255	17	22	15	20	25	17
4CFA-18S	1	29.4			38.6			25.9			25	30	20	25	30	25
4CFA-22S	1½	35.9			47.2			31.7			30	35	25	35	40	30
4CFA-26S	1¾	48.3			63.5			42.6			35	40	30	38	50	35
4CFA-34S	2	64.5			84.8			57.0			50	60	45	55	70	50

### Ratings for CD55 Liquid Line Char-Core® 123 sq. in. Filter Surface / 91 cu. in. Desiccant

Part Number	ODS (Inches)	R12		R22		R502		Tonnage Recommendations								
		Tons Flow 1#ΔP	Water Capacity		Tons Flow 1#ΔP	Water Capacity		Tons Flow 1#ΔP	Water Capacity		Comm. and Low Temperature			Air Conditioning		
			75° F	125° F		75° F	125° F		75° F	125° F	R12	R22	R502	R12	R22	R502
5CFA-34S	2½	91.4	2472	2145	120.2	2254	2200	80.7	2145	1800	65	85	55	70	100	60
5CFA-42S	2¾	92.3			120.9			81.3			—	—	—	—	—	—



Spare Parts List

WA/WAS Series Ball Valves

Catalog Series	586WA, 587WA	591WA, 592WA, 593WA, 594WA	595WA, 596WA
Seal Cap Nut	P587B-67	P590-67	P596WA-67
Seal Cap	P586WA-31	P591WA-31	P596WA-31
Slip Ring	P587WA-43	P590-43	P596WA-43
Seal Cap Gasket	P587B-20T	P3060X5-20T	P596WA-20T

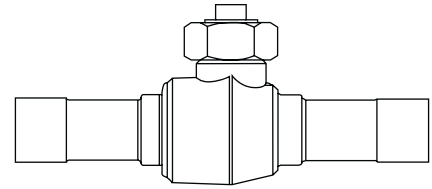

Tuffy Diaphragm Packless Valves

Catalog Series	114, 214	115, 116, 215, 216	216X7	217	234A
Spring	P204-11	P216-11	P216-11	P217-11	P204-11
Lower Stem	P214-20	P216-10	P115X3-21N	P217-21N	P214-20
Upper Stem	P214-7	P1032-7	P1032-7	P1032-7	P214-7
Diaphragms	P5502-6-6 (2)	P215-6 (Set)	P215-6 (Set)	P200-6 (Set)	P5502-6-6 (2)
Bonnet	P214-3	P206-3	P206-3	P201-3	P214-3
Handwheel	P1244-8R	P1070-8R	P1070-8R	P1070-8R	P1244-8R
Handwheel Screw	P200-14C	P200-14C	P200-14C	P200-14C	P200-14C
Cap and Chain	—	—	—	—	P617A-23-4 P617A-23-6

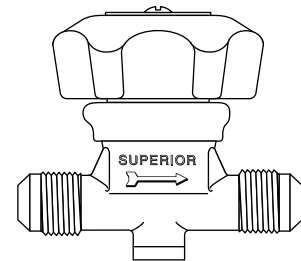

H-V Check Valves

Catalog Series	802, 803	804	185, 186, 805, 806	187, 188, 807, 808	809	884, 885, 886
Seat Assembly	P802A-24T	P804A-24T	P805C-24	P807C-24	P809C-24	P884C-30
Bonnet	P802B-2	P804A-2	P805C-2	P807C-2	P809C-2	P884C-2
Bonnet Gasket	P802-12	P804A-12	P290C-14	P292C-14	P294C-14	P295C-14
Spring	P802X1-11D	P802X1-11D	P805A-11	P807A-11	P809A-11	P884-11
Bonnets Bolts (4)	—	—	P290C-12	P292C-12	P11505-12SS	P295C-12

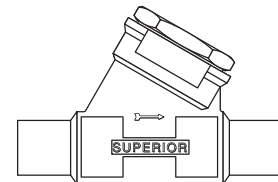



**Packed Angle Valves**

Catalog Series	600A, 600B	600AX7	617A	605	606B	607
Seal Cap	P600A-4	P600A-4	P600A-4	P605-4	P600A-4	P606-4
Seal Cap Gasket	P600A-11	P600A-11	P600A-11	P605-11	P600A-11	P606-11
Stem	P600A-2	P600A-2	P600A-2	P605-2	P503-2	P606-2
Packing Nut	P600-3	P600-3	P600-3	P605-3	P600-3	P606-3
Packing	P600-6B	P600-6B	P600-6B	P605-6B	P600-6B	P490-6
Packing Washer	P600-5	P600-5	P600-5	P605-5	P600-5	P606-5
¼" Cap & Chain	—	—	P617A-23-4	—	—	—
⅜" Cap & Chain	—	—	P617A-23-6	—	—	—
Schrader Core	—	P290X1-26	—	—	—	—
Outlet Cap	—	P9002-20	—	—	—	—

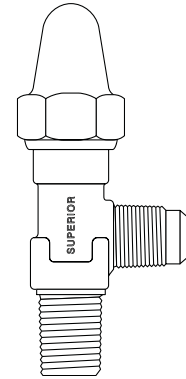

**CFA Shells**

Catalog Series	2CFA	3CFA	4CFA	5CFA
Spring	P11204-11	P11304-11	P11404-11	P11505A-11
Bolts (6)	P11204-12SS	P11304-12SS	P11404-12SS	P11506A-12SS
Cover	P11204-2	P11304-2A	P11404-2A	P11505B-2A
Access Valve	P11304-56	P11304-56	P11304-56	P11304-56
Gasket	AG2	AG3	AG4	AG5

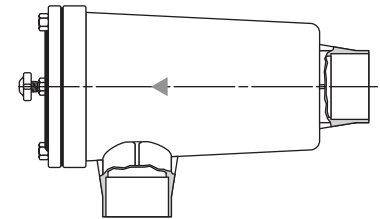

## Codes, Regulations and Specifications

Superior refrigeration and air conditioning components are made to various regulations and standards that currently exist in our industry. Where codes or specifications exist, Superior assures each product manufactured meets the maximum conditions of such codes. In cases where there are no code requirements, our manufacturing specifications require even tighter controls to ensure the optimum in good engineering practices. Briefly outlined below is a description of the various codes to which our products are manufactured. Detailed information or data is available upon request.

### Underwriters Laboratories, Inc.

We have submitted and obtained certified listings on many of our standard products. UL® listings are on file for such items as the hermetic eye sight glass, driers, fuse plugs, cylinder valves, flare fittings, etc. Many of these items have been approved for working pressures far greater than found in normal refrigeration applications. For instance, our hermetic eye sight glass is UL® approved for working pressures up to 500 psi (2,500 psi minimum bursting pressure).

The majority of Superior Refrigeration Products are UL® approved up to 700 PSIG maximum working pressure.

### Local and Municipal Codes

There are many municipal governing bodies with stringent codes for products used in their locality. Where Superior products are sold and used in these areas, the necessary approvals have been obtained.

### ANSI/ASHRAE 15 American National Standard for Mechanical Refrigeration

This code outlines specific requirements for the testing of pressure-relief valves.

*Note: The relief valves cataloged on pages 19–21 are the most complete and diversified line of approved relief valves available in the industry. In addition to relief valves, all other items in this catalog which come under the jurisdiction of this safety code are built to comply with its requirements.*

### ANSI-B70.1 American National Standard for Refrigeration Flare Type Fittings

This code outlines very accurately all the dimensions required for refrigeration flare-type fittings. Only fittings that comply with this code should be used in refrigeration work to ensure you the best performance.

### Society of Automotive Engineers

All requirements previously established by the SAE were incorporated in the ANSI-B70.1.

### European Directive 97/239/EC for Pressure Equipment

All of the relevant products meet the requirements of the European Union's Pressure Equipment Directive. Superior has received CE Certification on Category I and higher. These products are marked accordingly.

### ANSI-B57.1 Compressed Gas Cylinder Valve Outlet and Inlet Connections

Superior products comply with the requirements of this standard. Superior staff members sit on various cylinder gas committees charged with modifications and improvements to this code.

### Air Conditioning and Refrigeration Institute Standards

These standards are closely adhered to in our manufacturing operation to make certain that all Superior products meet the specifications and ratings outlined in the code.

### Pamphlet S-1, Compressed Gas Association, Inc., Safety Relief Device Standards

All Superior safety devices are built in accordance with CGA's recommendations. For a complete cross reference of Superior Part Numbers with CGA safety device numbers, contact our factory.

### Canadian Registration Numbers CRN# OC 8195

All shut-off and check valves.  
Expiry date: May 22, 2022

### CRN# OG 8195

All pressure-relief valves.  
Expiry date: April 19, 2022





***Beyond HVACR...  
Quality Products  
for Diverse Markets***

*Sherwood's years of experience in the diverse product lines of compressed gas propane, specialty gas and life support provide us with the technical expertise to meet your varied needs. Superior — A Sherwood Company is your partner for the best quality valves, delivered on time, at the best possible price!*





**SUPERIOR<sup>®</sup>**  
**A SHERWOOD COMPANY**

**Sherwood Valve, LLC**  
**Superior – A Sherwood Company**  
2200 North Main Street  
Washington, PA 15301

PHONE: **888.508.2583**

FAX: 800.416.0678

[superior@sherwoodvalve.com](mailto:superior@sherwoodvalve.com)

[www.sherwoodvalve.com](http://www.sherwoodvalve.com)



**MADE IN USA**